



NEWS 2020/2021



No to Blask!

Światło daje jasność. Natomiast lampy dodatkowo dodają też swój urok. Przygotowując najnowszą kolekcję lamp dbaliśmy właśnie o te dwa elementy – funkcjonalność i styl. Wszak lampy mają rozświetlać pomieszczenie, umożliwiać wygodną pracę czy relaks, ale też być ozdobą. Na kolejnych stronach zobaczycie garść świeżych pomysłów. Nowe lampy dotychczas do blisko 1000 innych, które rozwijamy już od niespełna dwóch dekad. Dzięki nim nasze propozycje są jeszcze bardziej różnorodne. Wierzymy, że każdy znajdzie coś dla siebie.

Wśród nowości nie brakuje modnych kolorów, odważnych designerskich rozwiązań, ale są też ponadczasowe barwy, eklektyczne, klasyczne modele. Jak zawsze przyświeca nam idea różnorodności materiałów. W nowych lampach znalazło się szkło, kryształ, metal oraz fantastyczne tkaninowe abażury.

Nowością jest też system szynoprzewodów ARGON T-RACK dający zupełnie świeże możliwości aranżacyjne. Niezmienne pozostaje też nasze przywiązanie do jakości. Z każdym nowym produktem, staramy się robić lampy jeszcze lepiej. Wierzymy, że zarówno dla nas jak i naszych Klientów istotne jest również to, że lampy wykonane są w całości w Polsce.

Sprawdźcie co nowego dla Was przygotowaliśmy.

Zdzisław Tomzik
właściciel ARGON LAMPY



ABSTRACT
05



AIDA
06



ALMADA
07



AVEIRO
08



BELLA
08



BEJA
09



BURGOS
11



CLAVA
12



CALVIA
13



CELIA
14



DORIA
15



HERMAN
17



FARON
19



FORM
19



IRUN
20



KARIN
21



KASER
23



LAGOS
25



LINEA
27



METIS
28



MARBELLA
29



MITOS
31



VIRGO
31



TOMAR
32



PONTE
33



SAGUNTO
35



SINES
37



SPEKIO
40



SINTRA
41



SKIATOS
42



TONI
43



TRINI
45



TROY
48



BANG
49



HAGA
49



BERGEN
50



DELTA
50



ELBRUS
51



HORTA
52



MURI
52



NET
53



T-RACK
54



ALMERIA
56



BILBAO
57



CADIZ
58



CRUZ
59



OVIEDO
60



-  lampy wiszące
-  zwisy (szynoprzewody)
-  plafony
-  plafony LED
-  reflektory (szynoprzewody)
-  kinkiety
-  lampy stołowe
-  lampy stojące



ABSTRACT 1696



ABSTRACT 1695

⊕ możliwość regulacji ramion lampy

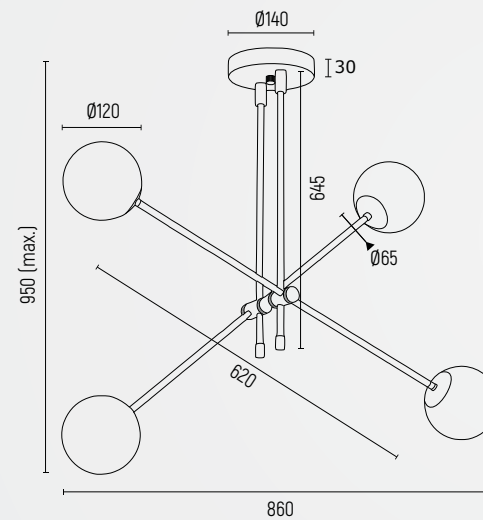

ABSTRACT

- 1695** - opal mat, miedz
- 1696** - opal mat, czarna struktura, el. miedzowane
- lampa wisząca 4 pt.
- 1695** - szkło, stal miedzowana
1696 - szkło, stal lakierowana, stal miedzowana
- E14 (nie zawiera źródła światła) / 230V | 4 x 7W (max)
- max. 950 wys. | 860 szer. | 140 gł.
- 3,5



AIDA 4337



AIDA 4338



AIDA 4339

AIDA

-  4337 - opal mat, biały struktura
-  4338 - opal mat, złoty struktura
-  4339 - opal mat, szalwia struktura
-  plafon LED
-  szkło, stal lakierowana
-  LED (zintegrowany) / 230V / 2450 lm / 3000 K | 22,5W
-  70 wys. | 335 szer. | 335 g.
-  1,3

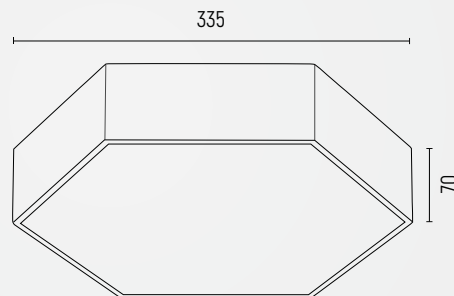



ALMADA 4231



ALMADA 4233









ALMADA 4232







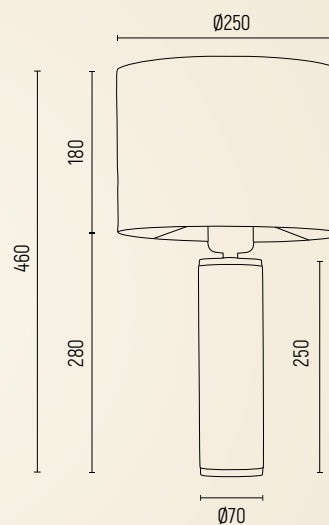
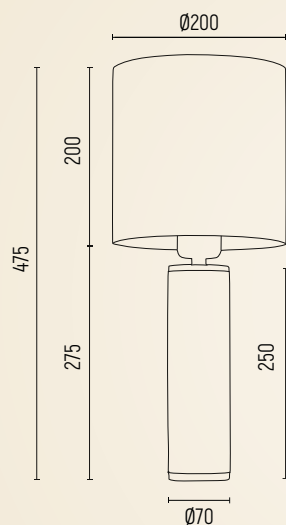

ALMADA 4234

ALMADA

-  4231 - biały, biały struktura, el. mosiądzowane
-  4233 - biały, czarny struktura, el. mosiądzowane
-  lampa stołowa 1 pt.
-  abażur, stal lakierowana, stal mosiądzowana
-  E27 (nie zawiera źródła światła) / 230V | 1 x 15W
-  475 wys. | 200 szer. | 200 gt.
-  1,5







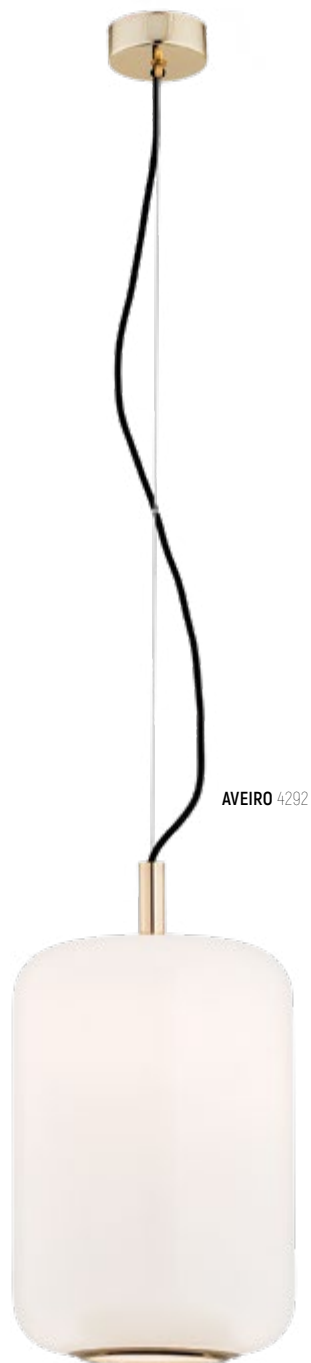
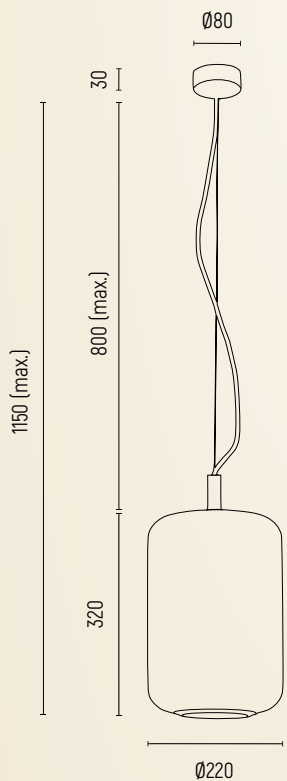

ALMADA

-  4232 - czarny ze złotym dekokrem, biały struktura, el. mosiądzowane
-  4234 - czarny ze złotym dekokrem, czarny struktura, el. mosiądzowane
-  lampa stołowa 1 pt.
-  abażur, stal lakierowana, stal mosiądzowana
-  E27 (nie zawiera źródła światła) / 230V | 1 x 15W
-  460 wys. | 250 szer. | 250 gt.
-  1,5



AVEIRO

-  opal mat, mosiądz
-  lampa wisząca 1 pt.
-  szkło, stal mosiądzowana
-  E27 (nie zawiera źródła światła) / 230V | 1 x 15W
-  linka max. 800, całość 1150 wys. | 220 szer. | 220 gt.
-  1,7



BELLA 1495









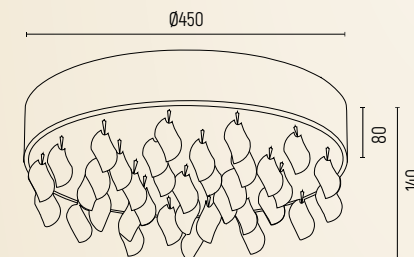

BELLA 1496



BELLA 1497



BELLA

-  1495 – czarny struktura, plexi biały połysk, kryształ przezroczysty
-  1496 – biały struktura, plexi biały połysk, kryształ przezroczysty
-  1497 – złoty struktura, plexi biały połysk, kryształ przezroczysty
-  plafon 3 pt.
-  stal lakierowana, plexi, kryształki
-  E27 (nie zawiera źródła światła) / 230V | 3 x 15W
-  140 wys. | 450 szer. | 450 gt.
-  4



BEJA 4359



BEJA 4360









BEJA 4361







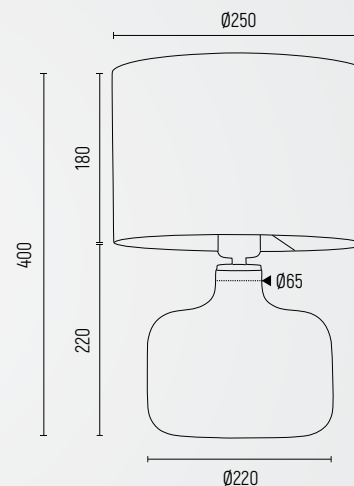
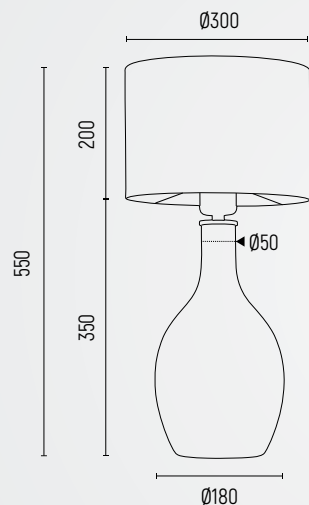

BEJA 4362

BEJA

-  **4359** – biało szary ze złotym dekokrem, biała podstawa połysk, el. mosiądzowane
-  **4360** – biało szary ze złotym dekokrem, szara podstawa połysk, el. mosiądzowane
-  lampa stołowa 1 pt.
-  abażur, szkło, stal mosiądzowana
-  E27 (nie zawiera źródła światła) / 230V | 1 x 15W (max)
-  550 wys. | 300 szer. | 300 gt.
-  1,4



BEJA

-  **4361** – biało szary ze złotym dekokrem, biała podstawa połysk, el. mosiądzowane
-  **4362** – biało szary ze złotym dekokrem, szara podstawa połysk, el. mosiądzowane
-  lampa stołowa 1 pt.
-  abażur, szkło, stal mosiądzowana
-  E27 (nie zawiera źródła światła) / 230V | 1 x 15W (max)
-  400 wys. | 250 szer. | 250 gt.
-  1,6



BEJA 4235



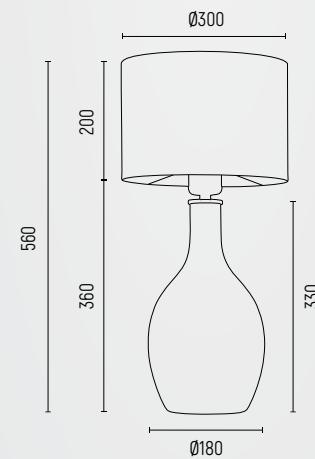

BEJA 4236





BEJA

 czarny ze złotym dekokrem, czarna podstawa połysk, el. mosiądzowane

 lampa stołowa 1 pt.

 abażur, szkło, stal mosiądzowana

 E27 (nie zawiera źródła światła) / 230V | 1 x 15W (max)

 4235 - 560 wys. | 300 szer. | 300 gt.
4236 - 405 wys. | 250 szer. | 250 gt.

 4235 - 1,3
4236 - 1,6

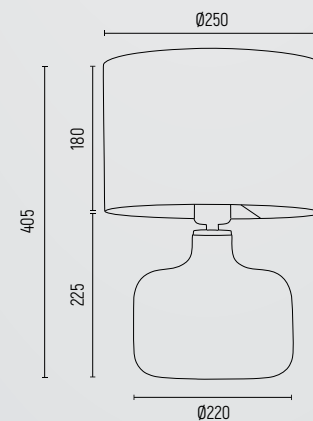



BURGOS 4211



BURGOS 4212



BURGOS 4213



BURGOS 1465













BURGOS 1466









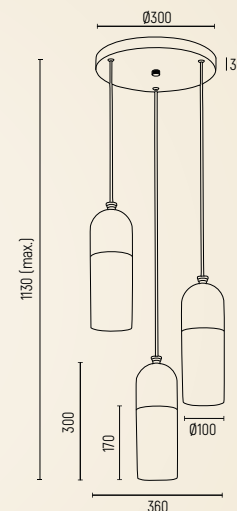
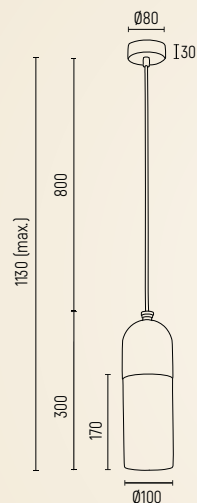



BURGOS 1467

BURGOS

-  4211 - opal mat, chrom
-  4212 - opal mat, mosiądz
-  4213 - opal mat, czarny struktura, el.mosiądzowane
-  lampa wisząca 1 pt.
-  4211 - szkło, stal chromowana
-  4212 - szkło, stal mosiądzowana
-  4213 - szkło, stal lakierowana, stal mosiądzowana
-  E27 (nie zawiera źródła światła) / 230V | 1 x 15W (max)
-  przewód max. 800, całość 1130 wys. | 100 szer. | 100 gt.
-  1



BURGOS

-  1465 - opal mat, chrom
-  1466 - opal mat, mosiądz
-  1467 - opal mat, czarny struktura, el. mosiądzowane
-  lampa wisząca 3 pt. okrągła podsufitka
-  1465 - szkło, stal chromowana
-  1466 - szkło, stal mosiądzowana
-  1467 - szkło, stal lakierowana, stal mosiądzowana
-  E27 (nie zawiera źródła światła) / 230V | 3 x 15W
-  przewód max. 800, całość 1130 wys. | 360 szer. | 360 gt.
-  3,8



CLAVA 1694



CLAVA 897



CLAVA 4270









CLAVA 4274











CLAVA 4275





CLAVA





-  złoty, czarna struktura
-  abażur, stal lakierowana
-  + możliwość regulacji ramion lampy

-  1694 - lampa wisząca 4 pt.
-  E27 (nie zawiera źródła światła) / 230V | 4 x 15W (max)
-  max. 1150, na zdjęciu 950 wys. | 1050 szer. | 350 g.
-  2,4

-  897 - lampa wisząca 2 pt.
-  E27 (nie zawiera źródła światła) / 230V | 2 x 15W (max)
-  max. 1300, pozycja na zdjęciu 1000 wys. | 1050 szer. | 250 g.
-  1,2

-  4275 - kinkiet 1 pt.
-  E27 (nie zawiera źródła światła) / 230V | 1 x 15W (max)
-  max. 610, pozycja na zdjęciu 230 wys. | 260 szer. | 590 g.
-  0,6

-  4274 - lampa biurkowa 1 pt.
-  E27 (nie zawiera źródła światła) / 230V | 1 x 15W (max)
-  490 wys. | 250 szer. | 490 g.
-  2,4

-  4270 - lampa stojąca 1 pt.
-  E27 (nie zawiera źródła światła) / 230V | 1 x 15W (max)
-  1350 (max 1870) wys. | 250 szer. | 700 g.
-  5,2

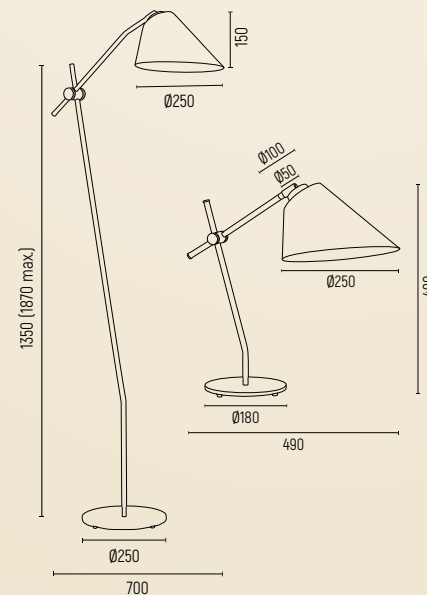
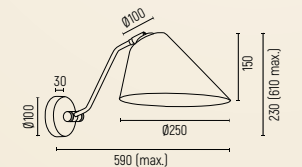
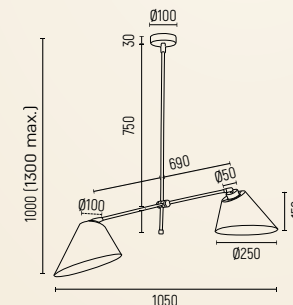
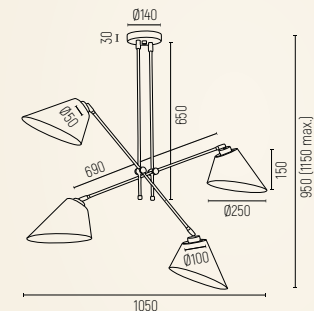



CALVIA 4241



CALVIA 4243



CALVIA 4242



CALVIA 4244





CALVIA 4245

CALVIA

-  4241 - opal, biały struktura
-  4242 - opal, czarny struktura
-  4243 - opal, granat struktura
-  4244 - opal, szalwia struktura
-  4245 - opal, koral struktura

 kinkiet 1 pt. z półką

 szkło, stal lakierowana

 LED [zintegrowany] / 230V / 1020 lm / 3000 K | 9W

 160 wys. | 330 szer. | 115 gł.

 1,6

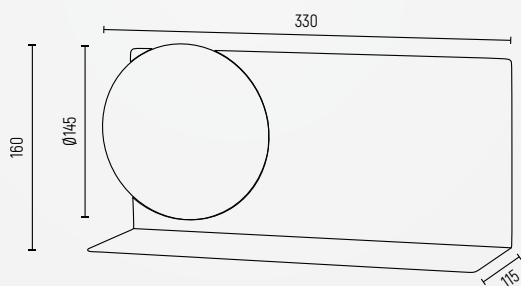



CELIA 4249



CELIA 4250



CELIA 4251



CELIA 4252



CELIA 4253

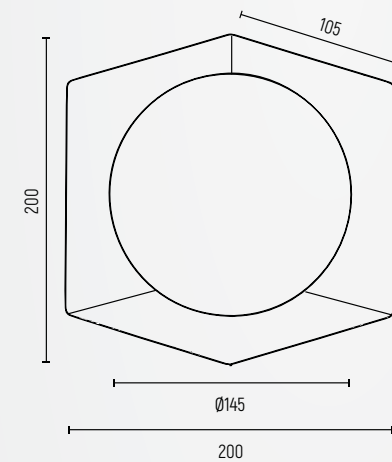

CELIA

-  4249 – opal, biały struktura
-  4250 – opal, koral struktura
-  4251 – opal, szalwia struktura
-  4252 – opal, granat struktura
-  4253 – opal, czarny struktura
-  kinkiet / plafon 1 pt.
-  szkło, stal lakierowana
-  LED (zintegrowany) / 230V / 1020 lm / 3000 K | 9W
-  200 wys. | 200 szer. | 50 gt.
-  0,6

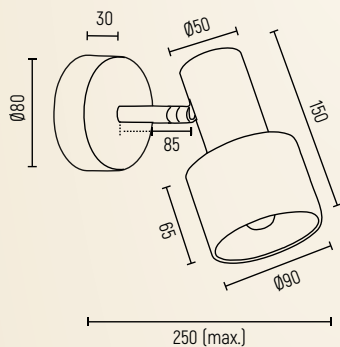

DORIA 4264



DORIA 4265



DORIA 4315

+ możliwość regulacji reflektorków



DORIA 4256

DORIA 4257

DORIA 4276

DORIA

-  **4264** – biały struktura, el. mosiędzowane
-  **4265** – czarny struktura, el. mosiędzowane
-  **4315** – szalwia struktura, el. mosiędzowane
-  kinkiet 1 pt.
-  stal lakierowana, stal mosiędzowana
-  E27 (nie zawiera źródła światła) / 230V | 1 x 15W
-  160 wys. | 90 szer. | max. 250 gt.
-  0,6

DORIA

-  **4256** – biały struktura, el. mosiędzowane
-  **4257** – czarny struktura, el. mosiędzowane
-  **4276** – szalwia struktura, el. mosiędzowane
-  lampa biurkowa 1 pt.
-  stal lakierowana, stal mosiędzowana
-  E27 (nie zawiera źródła światła) / 230V | 1 x 15W
-  460 wys. | 180 szer. | max. 280 gt.
-  2,2

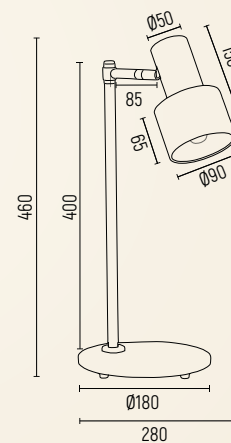

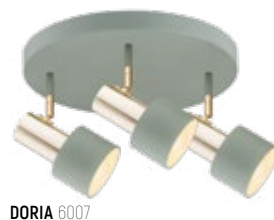
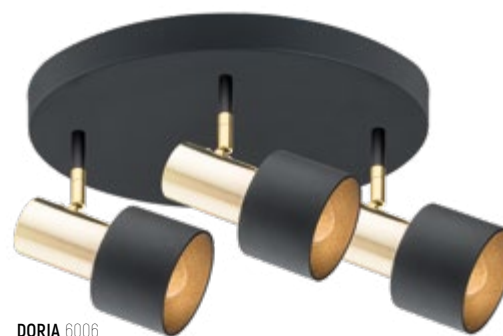
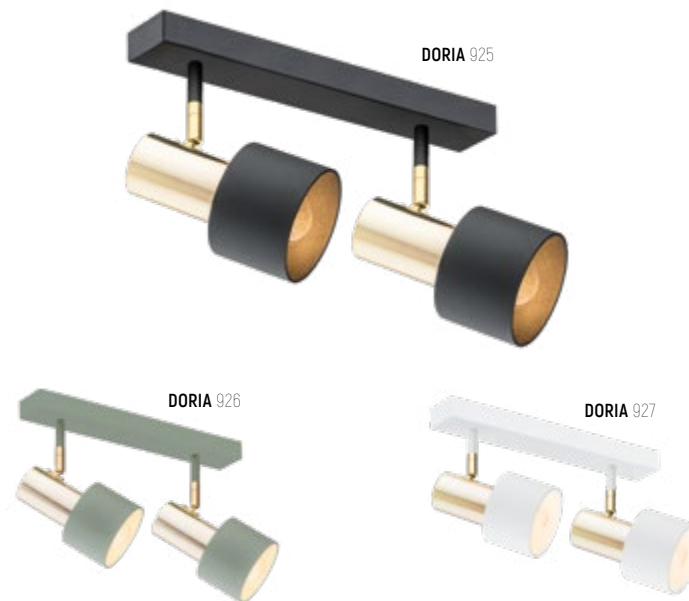



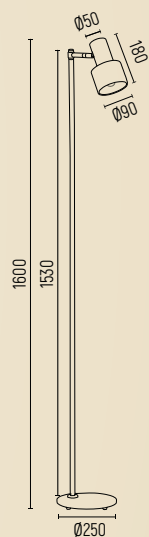

DORIA





-  4258 – biały struktura, el. mosiądzowane
-  4259 – czarny struktura, el. mosiądzowane
-  4271 – szalwia struktura, el. mosiądzowane
-  lampa stojąca 1 pt.
-  stal lakierowana, stal mosiądzowana
-  E27 (nie zawiera źródła światła) / 230V | 1 x 15W (max.)
-  1600 wys. | 250 szer. | 250 gt.
-  5,16



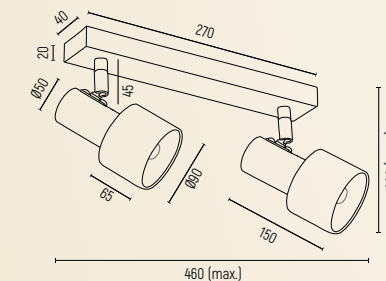



DORIA

-  925, 6006 – czarny struktura, el. mosiądzowane
-  926, 6007 – szalwia struktura, el. mosiądzowane
-  927, 6008 – biały struktura, el. mosiądzowane
-  stal lakierowana, stal mosiądzowana

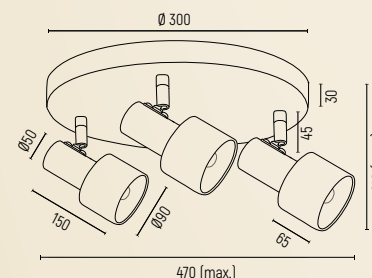



-  925, 926, 927 – kinkiet / plafon 2 pt.
-  E27 (nie zawiera źródła światła) / 230V | 2 x 15W (max.)
-  max. 200 wys. | max. 460 szer. | 150 gt.
-  1,2











-  6006, 6007, 6008 – kinkiet / plafon 3 pt.
-  E27 (nie zawiera źródła światła) / 230V | 3 x 15W (max.)
-  max. 210 wys. | max. 470 szer. | 470 gt.
-  1,8





 możliwość regulacji reflektorków





HERMAN





-  złoty, czarna struktura
-  abażur, stal lakierowana
-  możliwość regulacji lampy

-  **4279** – kinkiet 1 pt.
-  E27 (nie zawiera źródła światła) / 230V | 1 x 15W (max)
-  max. 250 wys. | 160 szer. | 320 gł.
-  0,7

-  **4300** – kinkiet 1 pt.
-  E27 (nie zawiera źródła światła) / 230V | 1 x 15W (max)
-  max. 210 wys. | 105 szer. | max. 250 gł.
-  0,4

-  **4280** – plafon 1 pt. mniejszy
-  E27 (nie zawiera źródła światła) / 230V | 1 x 15W (max)
-  165 wys. | 105 szer. | 105 gł.
-  0,4

-  **4247** – plafon 1 pt. większy
-  E27 (nie zawiera źródła światła) / 230V | 1 x 15W (max)
-  190 wys. | 160 szer. | 160 gł.
-  0,6

-  **1491** – plafon 3 pt.
-  E27 (nie zawiera źródła światła) / 230V | 3 x 15W (max)
-  190 wys. | 880 szer. | 105 gł.
-  2,4

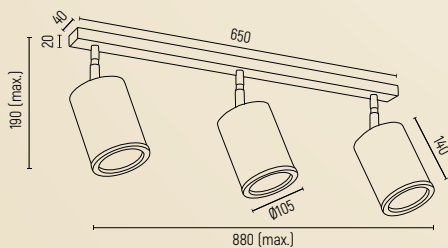
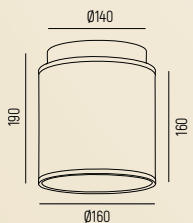
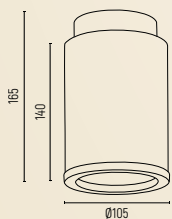
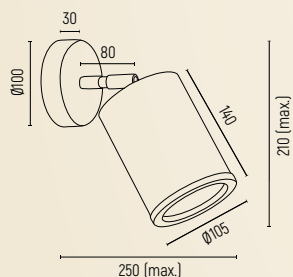
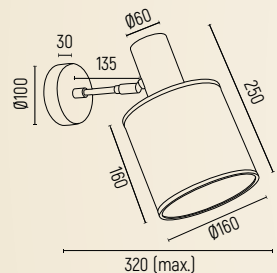

HERMAN 4279



HERMAN 4280



HERMAN 4300



HERMAN 4247



HERMAN 1491











HERMAN 1490







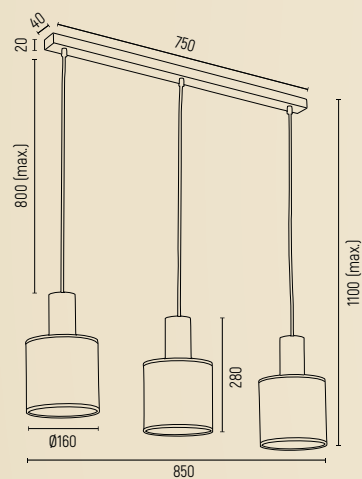

HERMAN 4248

HERMAN

-  1490 – złoty, czarny struktura
-  lampa wisząca 3 pł. listwa
-  abażur, stal lakierowana
-  E27 (nie zawiera źródła światła) / 230V | 3 x 15W (max)
-  przewód max. 800, całość 1100 wys. | 850 szer. | 160 g.
-  2,4





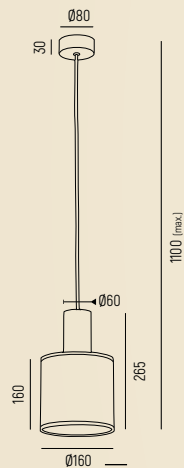

HERMAN

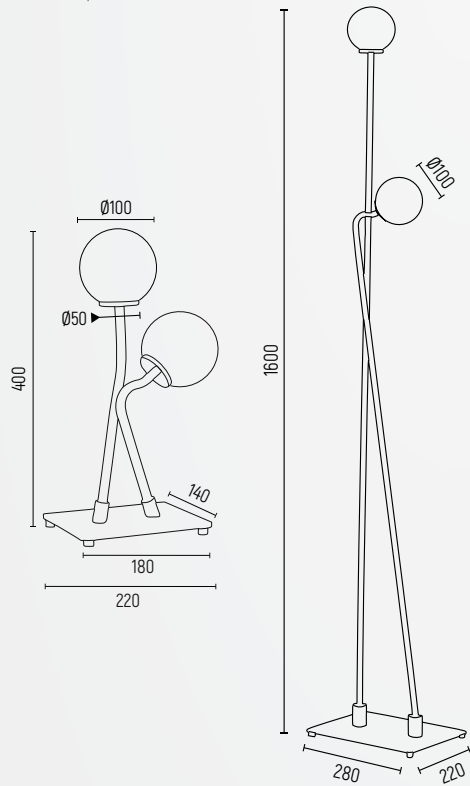
-  4248 – złoty, czarny struktura
-  lampa wisząca 1 pł.
-  abażur, stal lakierowana
-  E27 (nie zawiera źródła światła) / 230V | 1 x 15W (max)
-  przewód max. 800, całość 1100 wys. | 160 szer. | 160 g.
-  0,7





FARON

-  opal mat, czarna struktura, el. mosiądzowane
-  szkło, stal lakierowana, stal mosiądzowana
-  G9 (nie zawiera źródła światła) / 230V | 2 x 6W (max)
-  **892** - lampa stołowa 2 pt.
-  400 wys. | 220 szer. | 140 gt.
-  2,2
-  **893** - lampa stojąca 2 pt.
-  1600 wys. | 280 szer. | 220 gt.
-  5,1



FARON 892

FARON 893



FORM 1703



FORM 1701



FORM 1702

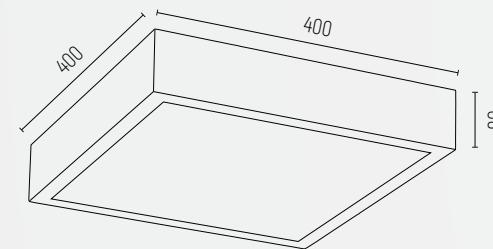









FORM

-  **1703** - czarny połysk, plexi biały połysk
-  **1701** - biały połysk, plexi biały połysk
-  **1702** - grafit połysk, plexi biały połysk
-  plafon 4 pt.
-  płyta drewniana laminowana lakierowana, plexi
-  E27 (nie zawiera źródła światła) / 230V | 4 x 15W (max)
-  80 wys. | 400 szer. | 400 gt.
-  3,7



IRUN

-  4266 - przezroczysty, el. mosiądzowane
-  4267 - dymny, el. mosiądzowane
-  4273 - opal, el. mosiądzowane
-  4277 - czarny połysk, el. mosiądzowane
-  lampa wisząca 1 pt.
-  szkło, stal mosiądzowana
-  E27 (nie zawiera źródła światła) / 230V | 1 x 15W (max)
-  przewód max.800, całość 1250 wys. | 250 szer. | 250 gt.
-  1,25

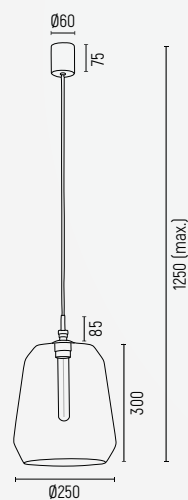

IRUN

-  4268 - przezroczysty, opal mat, el. mosiądzowane
-  4269 - dymny, opal mat, el. mosiądzowane
-  4272 - opal, el. mosiądzowane
-  4278 - czarny połysk, el. mosiądzowane
-  lampa wisząca 1 pt.
-  szkło, stal mosiądzowana
-  4268, 4269 - E14 (nie zawiera źródła światła) / 230V | 1 x 7W (max.)
-  4272, 4278 - E27 (nie zawiera źródła światła) / 230V | 1 x 15W (max)
-  przewód max.800, całość 1200 wys. | 300 szer. | 300 gt.
-  4268, 4269 - 1,4
-  4272, 4278 - 1,2

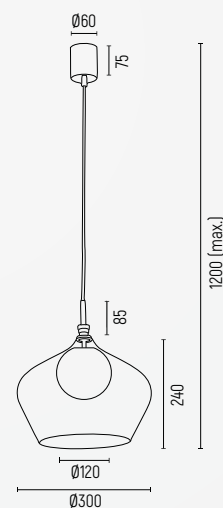

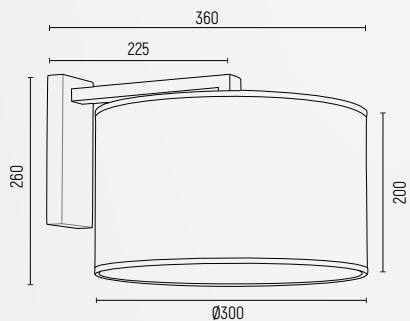

KARIN 4295



KARIN 4340



KARIN 4294



KARIN 4297









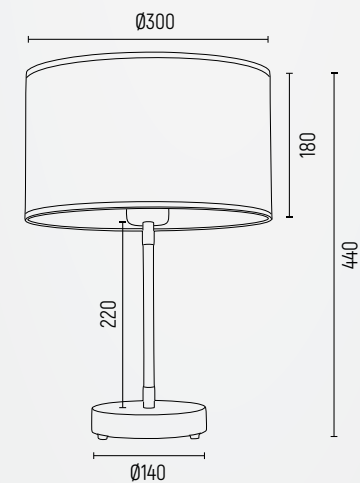

KARIN 4342



KARIN 4301



KARIN

-  4295 – złoty, czarny struktura
-  4340 – czarny ze złotym środkiem, czarny struktura
-  4294 – biały, biały struktura
-  kinkiet 1 pt.
-  abażur, stal lakierowana
-  E27 (nie zawiera źródła światła) / 230V | 1 x 15W (max)
-  260 wys. | 300 szer. | 360 gł.
-  0,75

KARIN

-  4297 – złoty, czarny struktura
-  4342 – czarny ze złotym środkiem, czarny struktura
-  4301 – biały, mosiądz
-  lampa stołowa 1 pt.
-  4297, 4342 – abażur, stal lakierowana
-  4301 – abażur, stal mosiądzowana,
-  E27 (nie zawiera źródła światła) / 230V | 1 x 15W (max)
-  440 wys. | 300 szer. | 300 gł.
-  1,35



KARIN

-  4291 – złoty, czarna struktura
-  4341 – czarny ze złotym środkiem, czarna struktura
-  4343 – biały, biały struktura
-  lampa wisząca 1 pt.
-  abażur, stal lakierowana
-  E27 (nie zawiera źródła światła) / 230V | 1 x 15W (max)
-  przewód max. 800, całość max. 1070 wys. | 400 szer. | 400 gł.
-  0,8

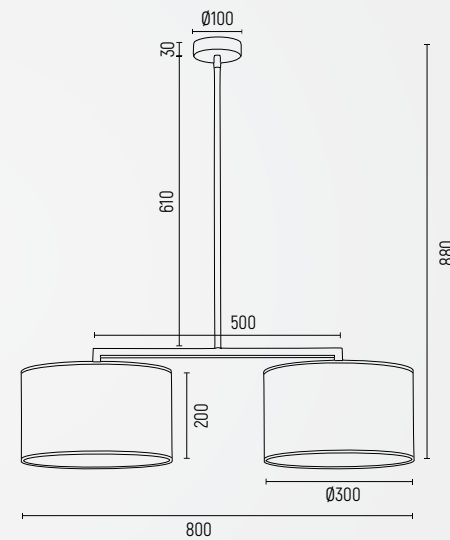
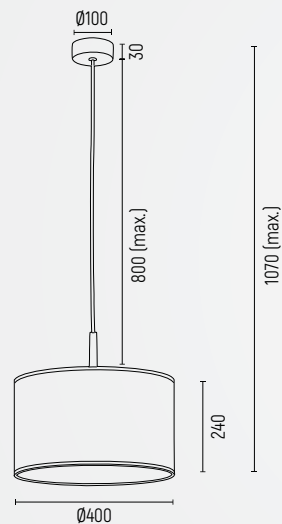



KARIN

-  898 – złoty, czarna struktura, el. mosiądzowane
-  899 – czarny ze złotym środkiem, czarna struktura, el. mosiądzowane
-  900 – biały, biały struktura, el. mosiądzowane
-  lampa wisząca 2 pt.
-  abażur, stal lakierowana, stal mosiądzowana
-  E27 (nie zawiera źródła światła) / 230V | 2 x 15W (max)
-  880 wys. | 800 szer. | 300 gł.
-  1,6





KASER

 biało szary ze złotym dekokrem, biały struktura, el. mosiądzowane

 abażur, stal lakierowana, stal mosiądzowana

 **4287** – lampa stojąca 1 pt.

 E27 (nie zawiera źródła światła) / 230V | 1 x 15W (max)

 1560 wys. | 400 szer. | 400 gt.

 5,9

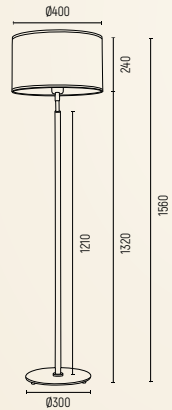



 **4293** – kinkiet 1 pt.

 E27 (nie zawiera źródła światła) / 230V | 1 x 15W (max)

 230 wys. | 250 szer. | 340 gt.

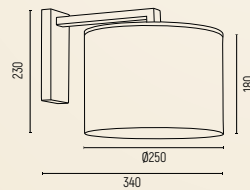
 0,75





 **4286** – lampa stołowa 1 pt.

 E27 (nie zawiera źródła światła) / 230V | 1 x 15W (max)

 470 wys. | 250 szer. | 250 gt.

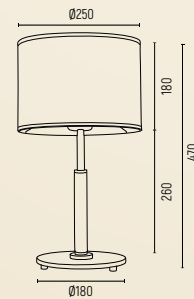
 2,3



 **4298** – lampa stołowa 1 pt.

 E27 (nie zawiera źródła światła) / 230V | 1 x 15W (max)

 445 wys. | 250 szer. | 250 gt.

 1,35

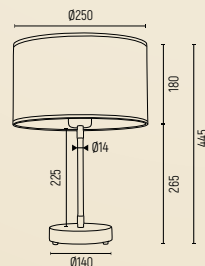

KASER 4287



KASER 4293



KASER 4286



KASER 4298



KASER 901









KASER 4344





KASER 4285

KASER

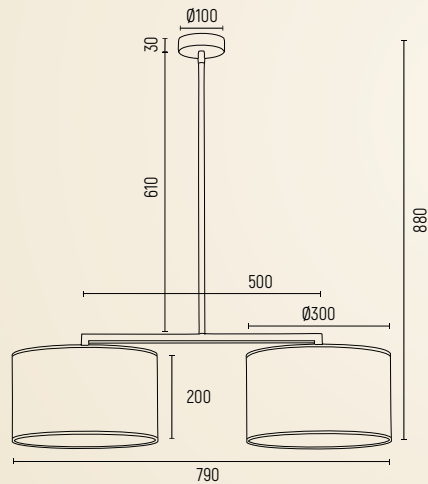

-  901 - biało szary ze złotym dekokrem, biały struktura, el. mosiądzowane
-  lampa wisząca 2 pt.
-  abażur, stal lakierowana, stal mosiądzowana
-  E27 (nie zawiera źródła światła) / 230V | 2 x 15W
-  880 wys. | 790 szer. | 300 gt.
-  1,6





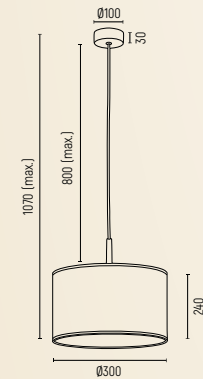

KASER

-  biało szary ze złotym dekokrem, biały struktura, el. mosiądzowane
-  abażur, stal lakierowana, stal mosiądzowana
-  E27 (nie zawiera źródła światła) / 230V | 1 x 15W

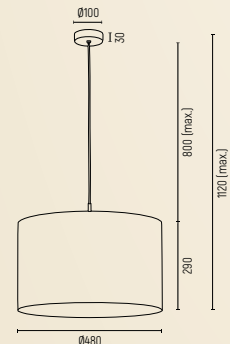

-  4344 - lampa wisząca 1 pt. mniejsza
-  przewód max.800, całość 1070 wys. | 300 szer. | 300 gt.
-  0,7



-  4285 - lampa wisząca 1 pt. większa
-  przewód max. 800, całość 1120 wys. | 480 szer. | 480 gt.
-  0,9

LAGOS 4208



LAGOS 889



LAGOS 4209



LAGOS 890



LAGOS 4210



LAGOS 891

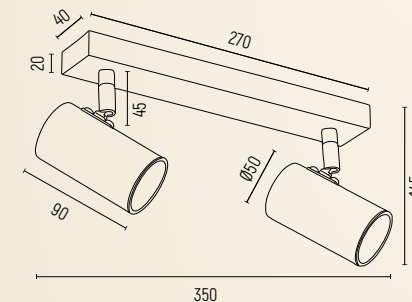
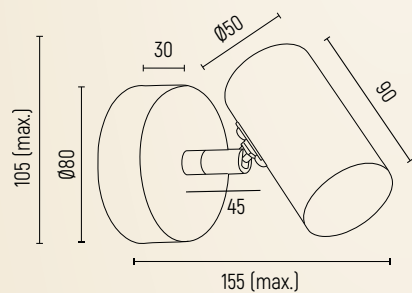

LAGOS

- 4208 – mosiądz, czarny mat
- 4209 – biały mat, el. mosiądzowane
- 4210 – czarny mat, el. mosiądzowane
- kinkiet 1 pt.
- stal lakierowana, stal mosiądzowana
- GU10 (nie zawiera źródła światła) / 230V | 1 x 5W (max)
- max. 105 wys. | 80 szer. | max. 155 gt.
- 0,26

możliwość zastosowania jako plafon i kinkiet oraz możliwość regulacji reflektorów

LAGOS

- 889 – mosiądz, czarny mat
- 890 – biały mat, el. mosiądzowane
- 891 – czarny mat, el. mosiądzowane
- plafon 2 pt.
- stal lakierowana, stal mosiądzowana
- GU10 (nie zawiera źródła światła) / 230V | 2 x 5W (max)
- 145 wys. | 350 szer. | 90 gt.
- 0,54



LAGOS

- 1474 - mosiądz, czarny mat
- 1475 - biały mat, el. mosiądzowane
- 1476 - czarny mat, el. mosiądzowane
- plafon 3 pt.
- stal lakierowana, stal mosiądzowana
- GU10 (nie zawiera źródła światła) / 230V | 3 x 5W (max)
- 145 wys. | 440 szer. | 90 gt.
- 0,8

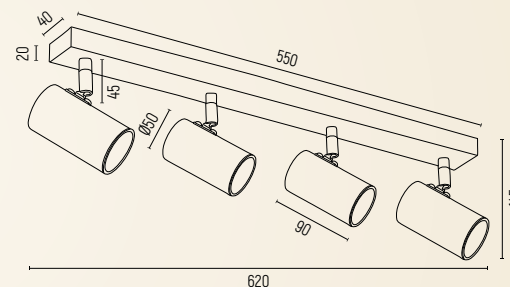
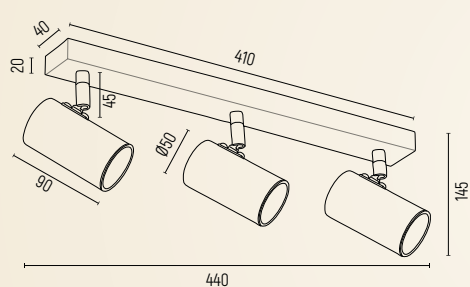





LAGOS



- 1688 - mosiądz, czarny mat
- 1689 - biały mat, el. mosiądzowane
- 1690 - czarny mat, el. mosiądzowane
- plafon 4 pt.
- stal lakierowana, stal mosiądzowana
- GU10 (nie zawiera źródła światła) / 230V | 4 x 5W (max)
- 145 wys. | 620 szer. | 90 gt.
- 1,1

możliwość zastosowania jako plafon i kinkiet oraz możliwość regulacji reflektorów

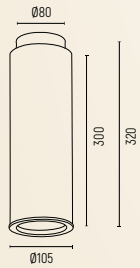

LINEA

-  złoty, czarny struktura
-  abażur, stal lakierowana
-  E27 (nie zawiera źródła światła) / 230V | 1 x 15W
-  0,5

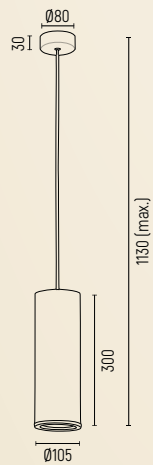

-  4281 - plafon 1 pt.
-  320 wys. | 105 szer. | 105 g.



-  4246 - lampa wisząca 1 pt.
-  przewód max. 800, całość 1130 wys. | 105 szer. | 105 g.

LINEA 4281



LINEA 4246



LINEA 1486







LINEA 1693



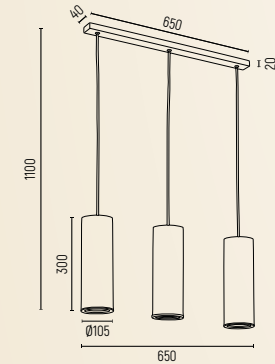



LINEA

-  złoty, czarny struktura
-  abażur, stal lakierowana

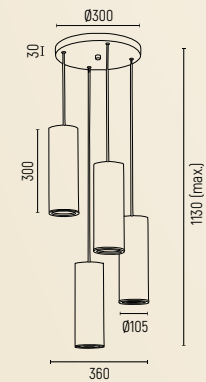

-  1486 - lampa wisząca 3 pt. listwa
-  E27 (nie zawiera źródła światła) / 230V | 3 x 15W
-  przewód max. 800, całość 1100 wys. | 650 szer. | 105 g.
-  1,3



-  1693 - lampa wisząca 4 pt. na okrągłej podsufitce
-  E27 (nie zawiera źródła światła) / 230V | 4 x 15W
-  przewód max. 800, całość 1130 wys. | 360 szer. | 360 g.
-  1,6

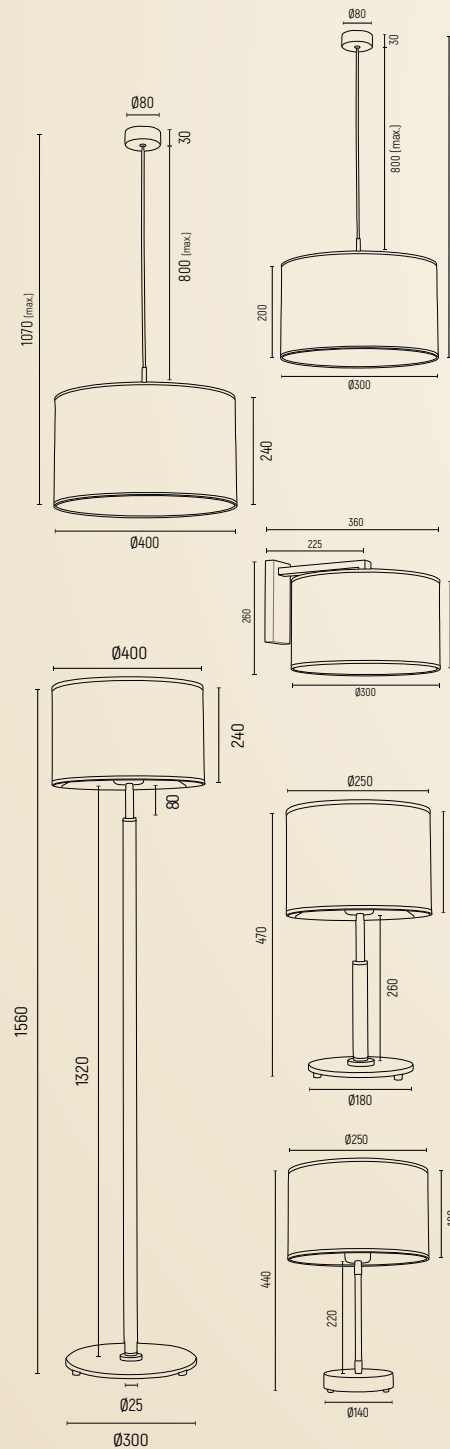





METIS

- czarny ze złotym dekokrem, czarna struktura, el. mosiądzowane
- abażur, stal lakierowana, stal mosiądzowana
- E27 (nie zawiera źródła światła) / 230V | 1 x 15W (max)
- 4345** – lampa wisząca 1 pt. mniejsza
przewód max. 800, całość 1030 wys. | 300 szer. | 300 gt.
0,6
- 4288** – lampa wisząca 1 pt. większa
przewód max. 800, całość 1070 wys. | 400 szer. | 400 gt.
0,8
- 4296** – kinkiet 1 pt.
260 wys. | 300 szer. | 360 gt.
0,75
- 4346** – lampa stojąca 1 pt.
1560 wys. | 400 szer. | 400 gt.
5,9
- 4289** – lampa stołowa 1 pt.
470 wys. | 250 szer. | 250 gt.
2,3
- 4302** – lampa stołowa 1 pt.
440 wys. | 250 szer. | 250 gt.
1,4



MARBELLA

-  4254 - opal mat, chrom
-  4255 - opal mat, mosiądz
-  kinkiet 1 pt.
-  szkło, stal chromowana, stal mosiądzowana
-  E27 (nie zawiera źródła światła) / 230V | 1 x 15W (max)
-  215 wys. | 180 szer. | 250 gt.
-  0,9

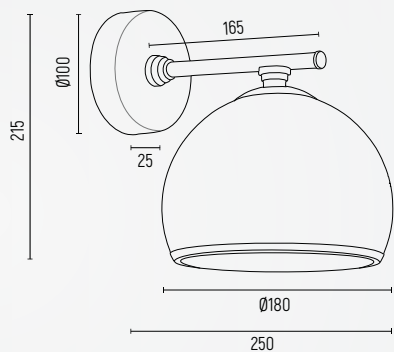



MARBELLA 1488



MARBELLA 1487



MARBELLA 2087



MARBELLA 2088

MARBELLA

-  **1487** - opal mat, chrom
-  **1488** - opal mat, mosiądz
-  lampa wisząca 3 pt.
-  szkło, stal chromowana, stal mosiądzowana
-  E27 (nie zawiera źródła światła) / 230V | 3 x 15W (max)
-  620 wys. | 550 szer. | 550 gt.
-  2,5

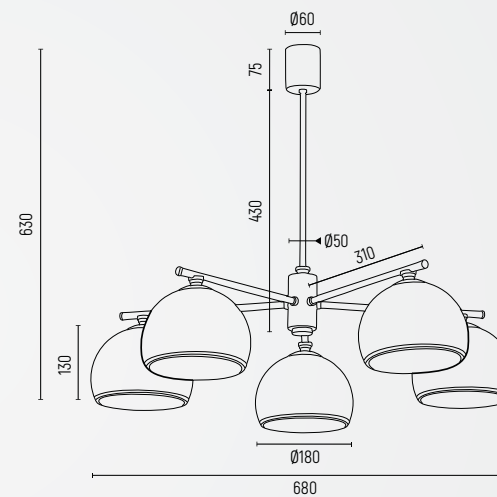
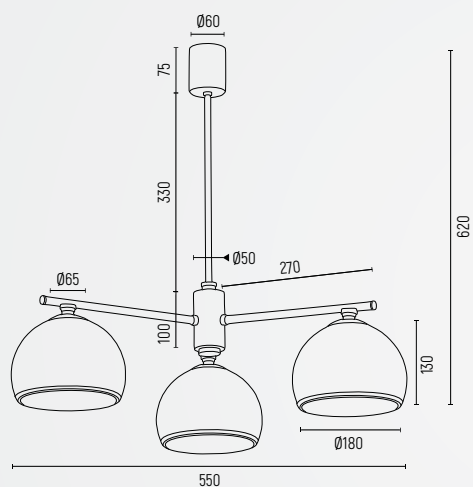

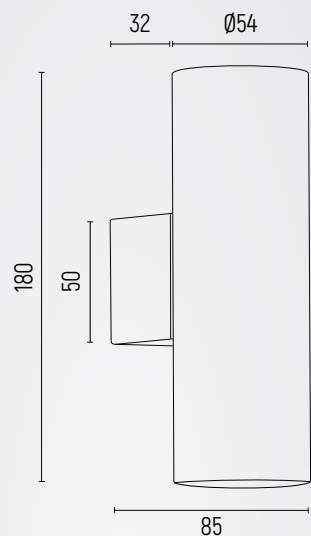

MARBELLA

-  **2087** - opal mat, chrom
-  **2088** - opal mat, mosiądz
-  lampa wisząca 5 pt.
-  szkło, stal chromowana, stal mosiądzowana
-  E27 (nie zawiera źródła światła) / 230V | 5 x 15W (max)
-  630 wys. | 680 szer. | 680 gt.
-  4,3



MITOS

-  909 - czarny struktura
-  910 - biały struktura
-  911 - złoty struktura
-  912 - chrom
-  913 - mosiądz
-  kinkiet 2 pt.

-  909, 910, 911 - stal lakierowana
-  912 - stal chromowana
-  913 - stal mosiądzowana

-  GU10 (nie zawiera źródła światła) / 230V | 2 x 5W (max)

-  180 wys. | 55 szer. | 85 gt.

-  0,5

MITOS 909



MITOS 910



MITOS 911



MITOS 912



MITOS 913



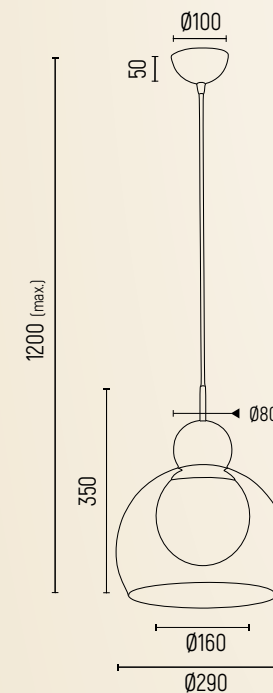

VIRGO 4237





VIRGO

-  4237 - przezroczysty, opal mat, mosiądz

-  lampa wisząca 1 pt.

-  szkło, stal mosiądzowana







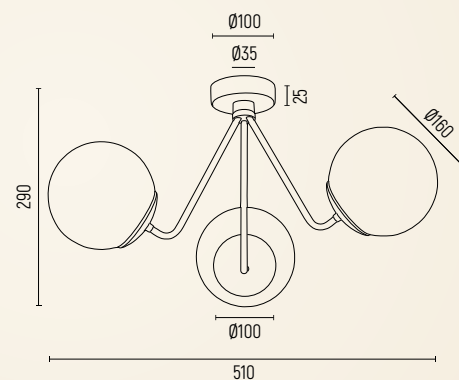



-  E27 (nie zawiera źródła światła) / 230V | 1 x 15W

-  przewód max.800, całość 1200 wys. | 290 szer. | 290 gt.

-  2,3



TOMAR

-  1477 - opal mat, chrom
-  1478 - opal mat, czarna struktura, el. mosiądzowane
-  1481 - opal mat, mosiądz
-  lampa wisząca 3 pł.
-  1477 - szkło, stal chromowana
-  1478 - szkło, stal lakierowana, stal mosiądzowana
-  1481 - szkło, stal mosiądzowana
-  E27 (nie zawiera źródła światła) / 230V | 3 x 15W (max)
-  290 wys. | 510 szer. | 510 gt.
-  2



PONTE 4347



PONTE 4348



PONTE 4349

PONTE

-  **4347** - błękit, ciemny mosiądz
-  **4348** - granat, ciemny mosiądz
-  **4349** - różowy, ciemny mosiądz
-  kinkiet 1 pł.
-  abażur welurowy, stal mosiądzowana
-  E27 (nie zawiera źródła światła) / 230V | 1 x 15W (max)
-  265 wys. | 180 szer. | 225 gt.
-  0,6

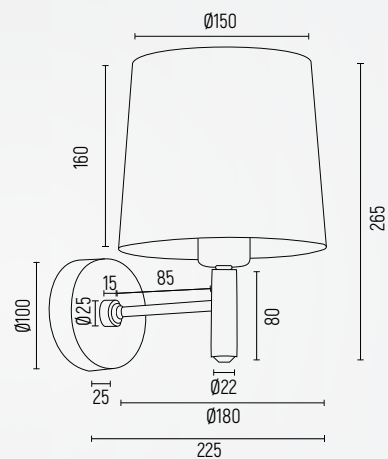



PONTE

-  1484 - błękit, ciemny mosiądz
-  1485 - granat, ciemny mosiądz
-  1498 - różowy, ciemny mosiądz
-  lampa wisząca 3 pt.
-  abażur welurowy, stal mosiądzowana
-  E27 (nie zawiera źródła światła) / 230V | 3 x 15W (max)
-  630 wys. | 475 szer. | 475 gt.
-  2,5

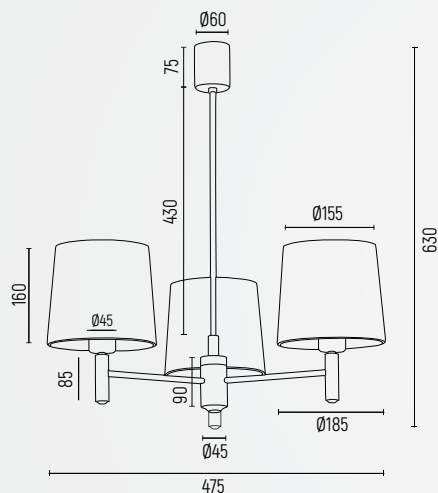

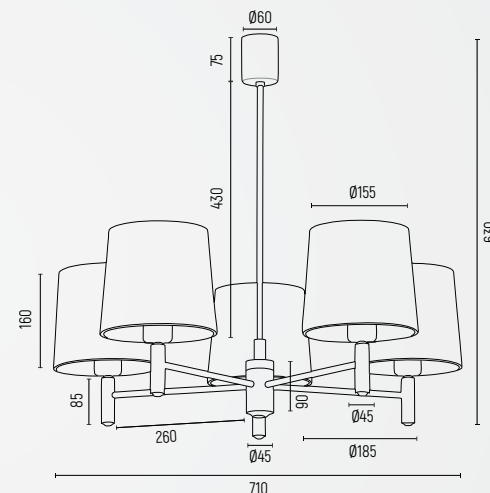

PONTE

-  2085 - błękit, ciemny mosiądz
-  2086 - granat, ciemny mosiądz
-  2089 - różowy, ciemny mosiądz
-  lampa wisząca 5 pt.
-  abażur welurowy, stal mosiądzowana
-  E27 (nie zawiera źródła światła) / 230V | 5 x 15W (max)
-  630 wys. | 710 szer. | 710 gt.
-  3,4



SAGUNTO

-  opal mat, mosiądz
-  szkło, stal mosiądzowana
-  E27 (nie zawiera źródła światła) / 230V | 1 x 15W (max)

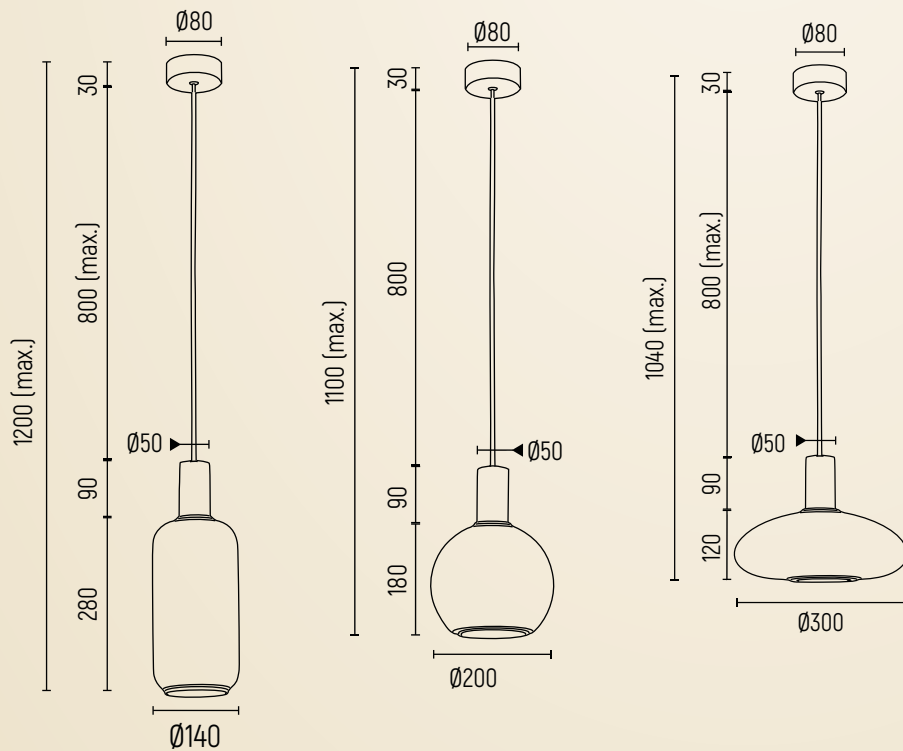

 **4356** – lampa wisząca 1 pt.

 przewód max. 800, całość 1200 wys. | 140 szer. | 140 g.

 0,7

 **4357** – lampa wisząca 1 pt.

 przewód max. 800, całość 1100 wys. | 200 szer. | 200 g.

 0,5

 **4358** – lampa wisząca 1 pt.

 przewód max. 800, całość 1040 wys. | 300 szer. | 300 g.

 0,8

SAGUNTO 4356



SAGUNTO 4358



SAGUNTO 4357

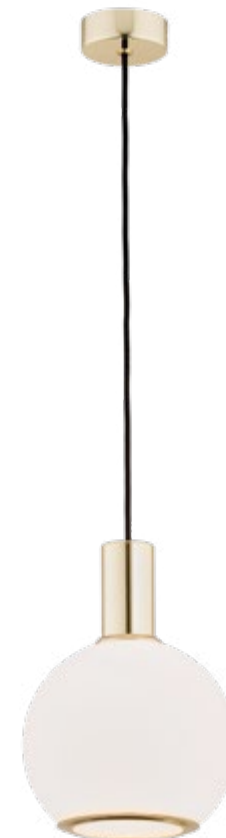

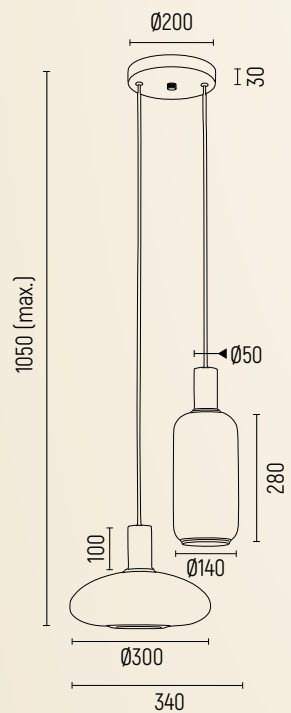

SAGUNTO 896





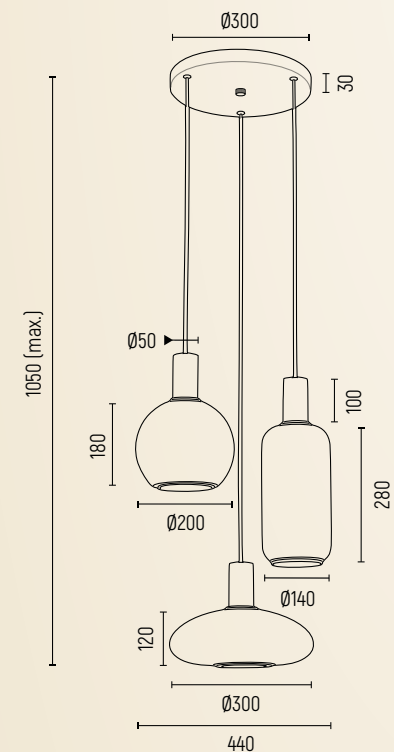



SAGUNTO 1489



SAGUNTO

-  **896** - opal mat, mosiądz
-  lampa wisząca 2 pt. na okrągłej podsufitce
-  szkło, stal mosiądzowana
-  E27 (nie zawiera źródła światła) / 230V | 2 x 15W (max)
-  przewód max. 800, całość 1050 wys. | 340 szer. | 300 g.
-  2

SAGUNTO

-  **1489** - opal mat, mosiądz
-  lampa wisząca 3 pt. na okrągłej podsufitce
-  szkło, stal mosiądzowana
-  E27 (nie zawiera źródła światła) / 230V | 3 x 15W (max)
-  przewód max. 800, całość 1050 wys. | 440 szer. | 440 g.
-  3



SINES 4215



SINES 4214



SINES 4216



SINES 4217











SINES 4218



SINES 4219

SINES

-  4215 - biały struktura, el. mosiędżowane
-  4214 - szalwia struktura, el. mosiędżowane
-  4216 - granat struktura, el. mosiędżowane
-  lampa wisząca 1 pt.
-  stal lakierowana, stal mosiędżowana
-  E27 (nie zawiera źródła światła) / 230V | 1 x 15W (max)
-  przewód max. 800, całość 1030 wys. | 140 szer. | 140 gt.
-  0,6

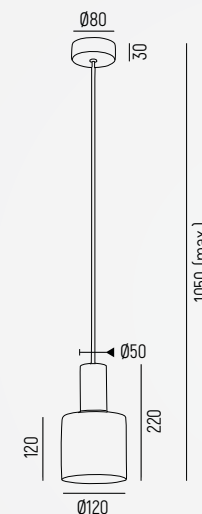

SINES

-  4217 - szalwia struktura, el.mosiędżowane
-  4218 - koral struktura, el.mosiędżowane
-  4219 - czarny struktura, el.mosiędżowane
-  lampa wisząca 1 pt.
-  stal lakierowana, stal mosiędżowana
-  E27 (nie zawiera źródła światła) / 230V | 1 x 15W (max)
-  przewód max. 800, całość 1050 wys. | 120 szer. | 120 gt.
-  0,6

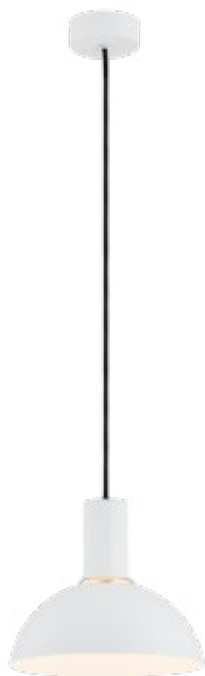

SINES 4220





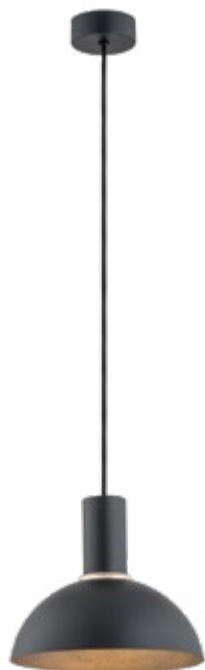





SINES 4221



SINES 4222

SINES

-  4220 - biały struktura, el.mosiądzowane
-  4221 - granat struktura, el.mosiądzowane
-  4222 - czarny struktura, el.mosiądzowane
-  lampa wisząca 1 pt.
-  stal lakierowana, stal mosiądzowana
-  E27 (nie zawiera źródła światła) / 230V | 1 x 15W (max)
-  przewód max. 800, całość 1030 wys. | 220 szer. | 220 g.
-  0,8

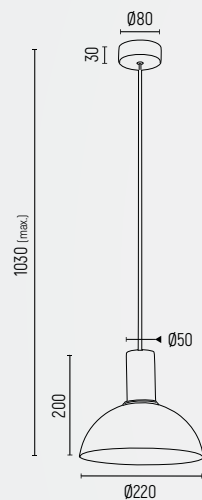

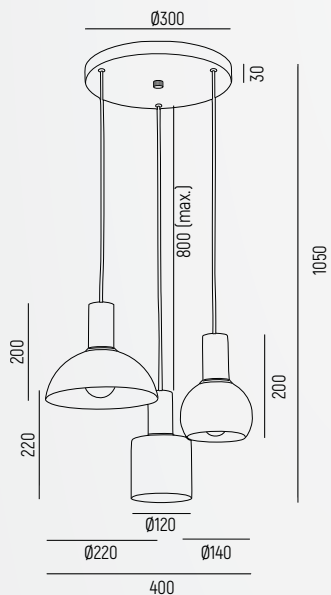

SINES

-  **1468** - biały struktura, el. mosiądzowane
-  **1469** - koral struktura, el. mosiądzowane
-  **1470** - szalwia struktura, el. mosiądzowane
-  **1471** - granat struktura, el. mosiądzowane
-  **1472** - czarny struktura, el. mosiądzowane
-  **1479** - mix (szalwia, koral, granat) struktura, el. mosiądzowane
-  **1480** - mix (biały, czarny, koral) struktura, el. mosiądzowane
-  lampa wisząca 3 pł. okrągła podsufitka
-  stal lakierowana, stal mosiądzowana
-  E27 (nie zawiera źródła światła) / 230V | 3 x 15W (max.)
-  przewód max.800, całość 1050 wys. | 400 szer. | 400 gł.
-  2



SINES 1468

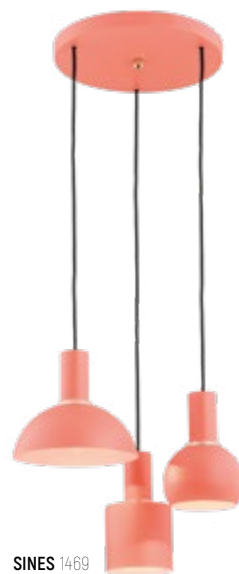

SINES 1469



SINES 1470



SINES 1471



SINES 1472



SINES 1479



SINES 1480



SPEKIO

-  4260 – lustro, chrom
-  4261 – lustro, mosiądz
-  kinkiet LED kwadratowy - lusterko
-  4260 – szkło-lustro, stal chromowana
-  4261 – szkło-lustro, stal mosiądzowana
-  LED (zintegrowany) / 230V / 1150 lm / 3000 K | 9W
-  200 wys. | 200 szer. | 40 gt.
-  1,3

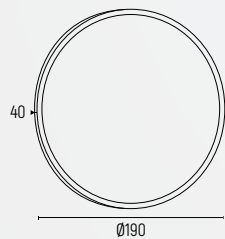
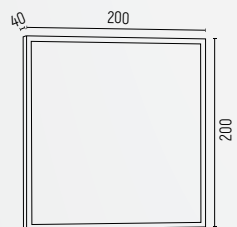

-  4262 – lustro, chrom
-  4263 – lustro, mosiądz
-  kinkiet LED okrągły - lusterko
-  4262 – szkło-lustro, stal chromowana
-  4263 – szkło-lustro, stal mosiądzowana
-  LED (zintegrowany) / 230V / 1150 lm / 3000 K | 9W
-  190 wys. | 190 szer. | 40 gt.
-  1



SPEKIO 4260



SPEKIO 4261



SPEKIO 4262



SPEKIO 4263



SPEKIO 4335



SPEKIO 4336

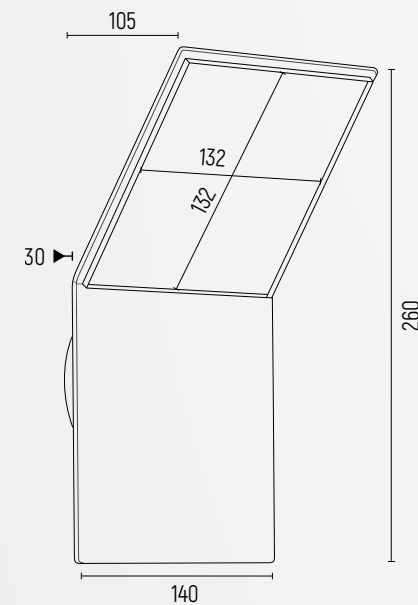





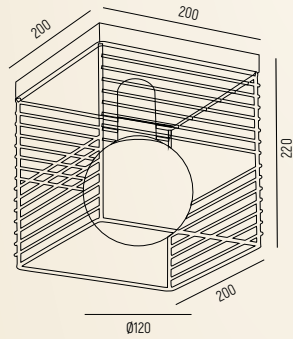



SPEKIO

-  4335 – lustro, biały struktura
-  4336 – lustro, czarny struktura
-  kinkiet 1 pł. z daszkiem - lusterko
-  szkło-lustro, stal lakierowana
-  G9 (nie zawiera źródła światła) / 230V | 1 x 6W (max)
-  260 wys. | 140 szer. | 105 gt.
-  1,3



SINTRA

-  4223 – opal mat, biały struktura, el. mosiądzowane
-  4224 – opal mat, szalwia struktura, el. mosiądzowane
-  4225 – opal mat, złoty struktura, el. mosiądzowane
-  4226 – opal mat, czarny struktura, el. mosiądzowane
-  plafon 1 pt.
-  szkło, stal lakierowana, stal mosiądzowana
-  E14 (nie zawiera źródła światła) / 230V | 1 x 7W (max)
-  220 wys. | 200 szer. | 200 gt.
-  1,4



SINTRA 4223



SINTRA 4224



SINTRA 4225



SINTRA 4226



SINTRA 4227







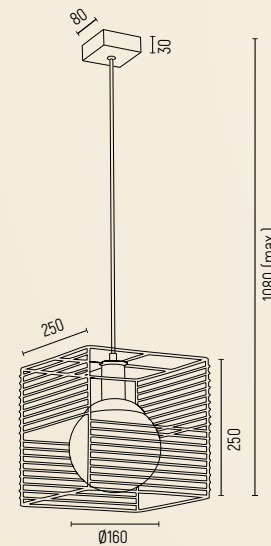

SINTRA 4228

SINTRA 4230

SINTRA 4229



SINTRA

-  4227 – opal mat, biały struktura, el. mosiądzowane
-  4228 – opal mat, szalwia struktura, el. mosiądzowane
-  4229 – opal mat, złoty struktura, el. mosiądzowane
-  4230 – opal mat, czarny struktura, el. mosiądzowane
-  lampa wisząca 1 pt.
-  szkło, stal lakierowana, stal mosiądzowana
-  E14 (nie zawiera źródła światła) / 230V | 1 x 7W (max)
- przewód max.800, całość 1080 wys. | 250 szer. | 250 gt.
- 1,4



SKIATOS 914



SKIATOS 915



SKIATOS 916









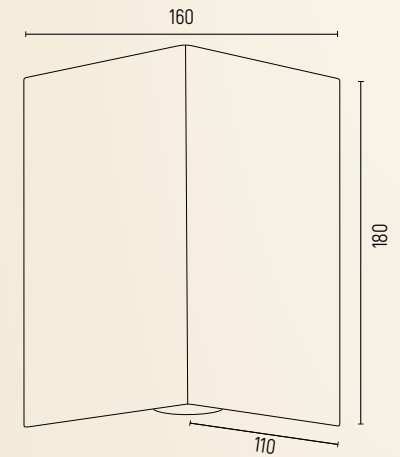

SKIATOS 917



SKIATOS 918







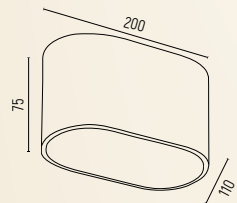

SKIATOS

-  **914** - czarna struktura
-  **915** - biała struktura
-  **916** - złoty struktura
-  **917** - chrom
-  **918** - miedz
-  kinkiet 2 pt.
-  **914, 915, 916** - stal lakierowana
-  **917** - stal chromowana
-  **918** - stal miedzowana
-  GU10 (nie zawiera źródła światła) / 230V | 2 x 5W (max)
-  180 wys. | 160 szer. | 80 gł.
-  0,6



TONI

-  **4371** – opal mat, czarny struktura
-  **4372** – opal mat, czarny struktura ze złotym paskiem
-  **4373** – opal mat, biały struktura
-  **4374** – opal mat, biały struktura ze złotym paskiem
-  **4375** – opal mat, chrom
-  **4376** – opal mat, złoty struktura
-  plafon 1 pt.
-  szkło, stal lakierowana, stal chromowana
-  E27 (nie zawiera źródła światła) / 230V | 1 x 15W [max]
-  75 wys. | 200 szer. | 110 gł.
-  0,9



TONI 4371



TONI 4372



TONI 4373



TONI 4374



TONI 4375



TONI 4376



TONI 903



TONI 904



TONI 905



TONI 906









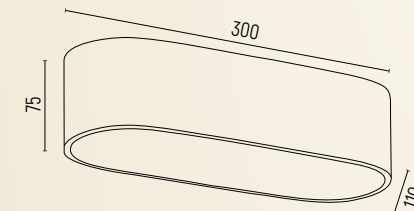



TONI 907



TONI 908







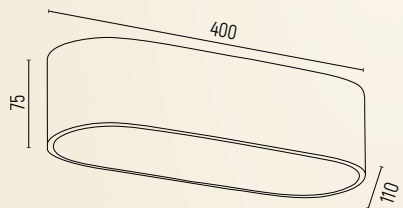





TONI

-  **903** – opal mat, czarny struktura
-  **904** – opal mat, czarny struktura ze złotym paskiem
-  **905** – opal mat, biały struktura
-  **906** – opal mat, biały struktura ze złotym paskiem
-  **907** – opal mat, chrom
-  **908** – opal mat, złoty struktura
-  plafon 2 pt.
-  szkło, stal lakierowana, stal chromowana
-  E27 (nie zawiera źródła światła) / 230V | 2 x 15W [max]
-  75 wys. | 300 szer. | 110 gł.
-  1,5



TONI

-  919 - opal mat, czarny struktura
-  920 - opal mat, czarny struktura ze złotym paskiem
-  921 - opal mat, biały struktura
-  922 - opal mat, biały struktura ze złotym paskiem
-  923 - opal mat, chrom
-  924 - opal mat, złoty struktura
-  plafon 2 pt.
-  szkło, stal lakierowana, stal chromowana
-  E27 (nie zawiera źródła światła) / 230V | 2 x 15W [max]
-  75 wys. | 400 szer. | 110 gł.
-  1,8



TONI 919



TONI 920



TONI 921



TONI 922



TONI 923



TONI 924



TONI 6000



TONI 6001



TONI 6002



TONI 6003









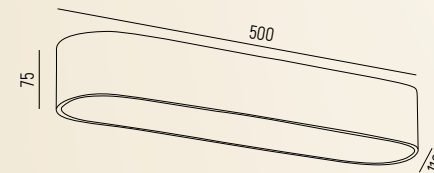



TONI 6004



TONI 6005



TONI

-  6000 - opal mat, czarny struktura
-  6001 - opal mat, czarny struktura ze złotym paskiem
-  6002 - opal mat, biały struktura
-  6003 - opal mat, biały struktura ze złotym paskiem
-  6004 - opal mat, chrom
-  6005 - opal mat, złoty struktura
-  plafon 3 pt.
-  szkło, stal lakierowana, stal chromowana
-  E27 (nie zawiera źródła światła) / 230V | 3 x 15W [max]
-  75 wys. | 500 szer. | 110 gł.
-  2,2





TRINI 4352



TRINI 4331



TRINI 4333



TRINI 4316

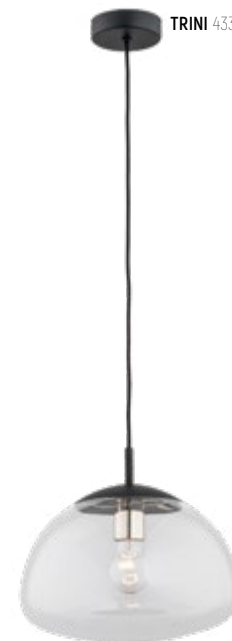



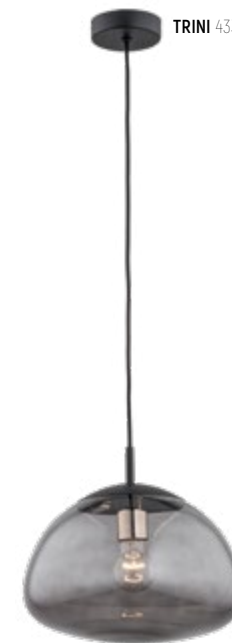





TRINI 4332









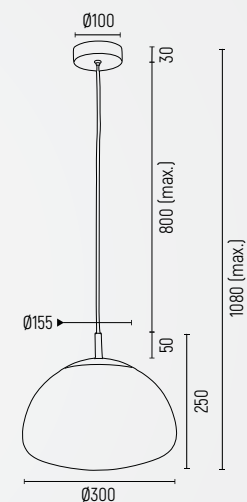
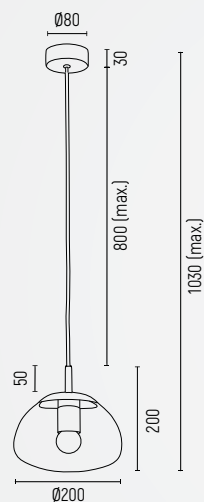

TRINI 4334

TRINI

-  4352 - opal mat, el. mosiądzowane
-  4331 - przezroczysty, czarny mat, el. mosiądzowane
-  4333 - dymny, czarny mat, el. mosiądzowane
-  lampa wisząca 1 pt. S
-  szkło, stal mosiądzowana, stal lakierowana
-  E27 (nie zawiera źródła światła) / 230V | 1 x 15W (max)
-  przewód max. 800, całość 1030 wys. | 200 szer. | 200 gt.
-  1,2



TRINI

-  4316 - opal mat, el. mosiądzowane
-  4332 - przezroczysty, czarny mat, el. mosiądzowane
-  4334 - dymny, czarny mat, el. mosiądzowane
-  lampa wisząca 1 pt. M
-  szkło, stal mosiądzowana, stal lakierowana
-  E27 (nie zawiera źródła światła) / 230V | 1 x 15W (max)
-  przewód max. 800, całość 1080 wys. | 300 szer. | 300 gt.
-  2



TRINI 4317



TRINI 4351



TRINI 4350











TRINI 1492







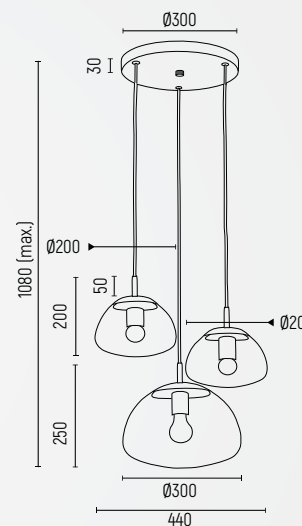
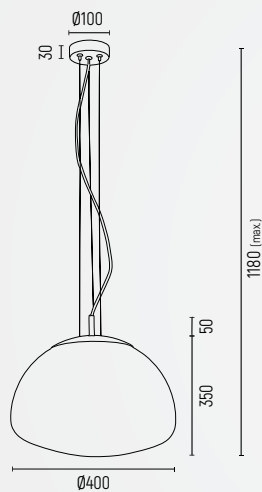

TRINI 1493

TRINI

-  **4317** - opal mat, el. mosiądzowane
-  **4351** - przezroczysty, czarny mat, el. mosiądzowane
-  **4350** - dymny, czarny mat, el. mosiądzowane
-  lampa wisząca 1 pt. L
-  szkło, stal mosiądzowana, stal lakierowana
-  E27 (nie zawiera źródła światła) / 230V | 1 x 15W (max)
-  przewód max. 800, całość 1180 wys. | 400 szer. | 400 gt.
-  3



TRINI

-  **1492** - przezroczysty, czarny mat, el. mosiądzowane
-  **1493** - dymny, czarny mat, el. mosiądzowane
-  lampa wisząca 3 pt. na okrągłej podsufitce
-  szkło, stal lakierowana, stal mosiądzowana
-  E27 (nie zawiera źródła światła) / 230V | 3 x 15W (max)
-  przewód max. 800, całość 1080 wys. | 440 szer. | 440 gt.
-  4,2







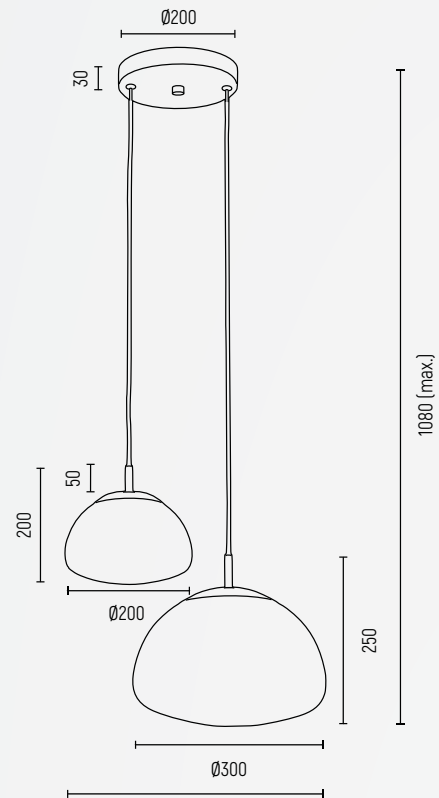

TRINI 1494

TRINI 902







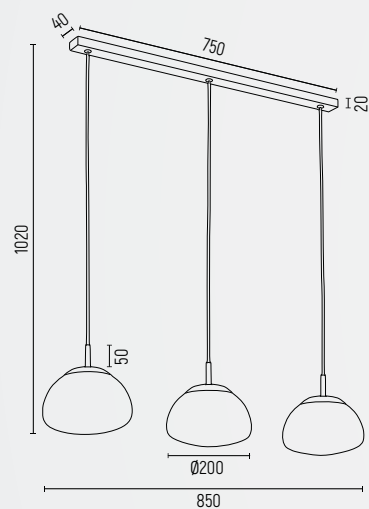

TRINI

-  **1494** - opal mat, el. mosiądzowane
-  lampa wisząca 3 pt. listwa
-  szkło, stal mosiądzowana
-  E27 (nie zawiera źródła światła) / 230V | 3 x 15W (max)
-  przewód max. 800, całość 1020 wys. | 850 szer. | 200 g.
-  3,2



TRINI

-  **902** - opal mat, el. mosiądzowane
-  lampa wisząca 2 pt. okrągła podsufitka
-  szkło, stal mosiądzowana
-  E27 (nie zawiera źródła światła) / 230V | 2 x 15W (max)
-  przewód max. 800, całość 1080 wys. | 450 szer. | 300 g.
-  3,1





TROY 4283





TROY 4282



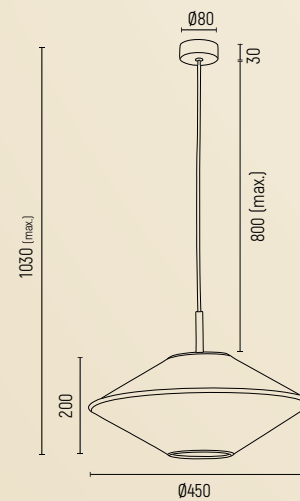
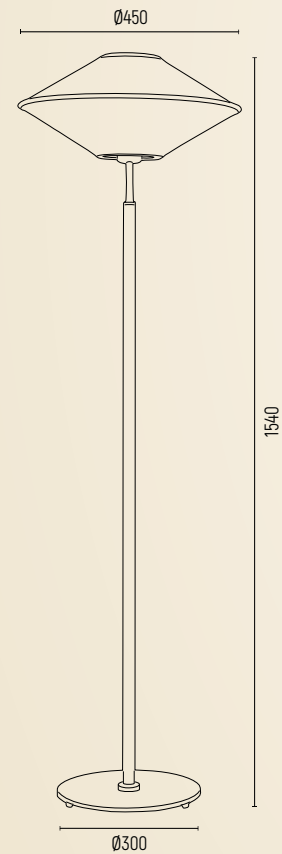





TROY 4284





TROY

-  beżowy z czarnym przeszyciem, czarna struktura
-  abażur, stal lakierowana
-  E27 (nie zawiera źródła światła) / 230V | 1 x 15W (max)

-  **4283** - lampa stojąca 1 pt.
-  1540 wys. | 450 szer. | 450 gt.
-  5,9

-  **4282** - lampa wisząca 1 pt.
-  przewod max. 800, całość 1030 wys. | 450 szer. | 450 gt.
-  0,7

-  **4284** - lampa stołowa 1 pt.
-  430 wys. | 350 szer. | 350 gt.
-  1,75

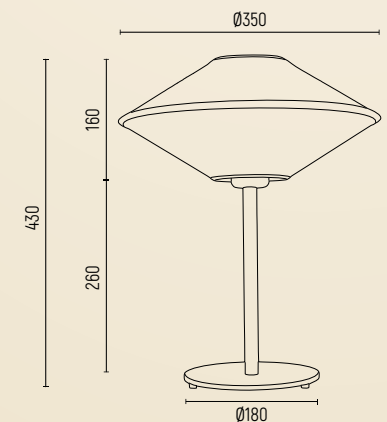

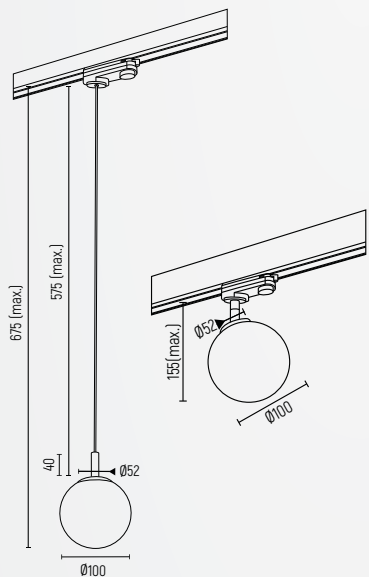

BANG 4307

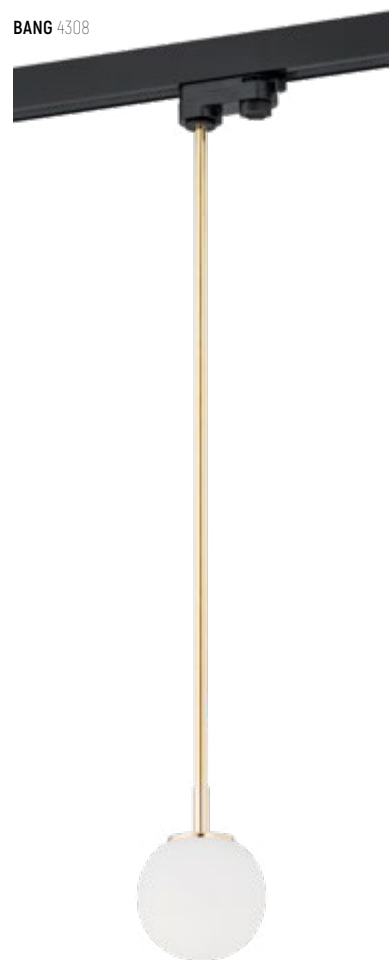

BANG 4308

BANG

-  opal mat, mosiądz, czarny
-  szkło, stal mosiądzowana, tworzywo sztuczne
-  G9 (nie zawiera źródła światła) / 230V | 1 x 6W (max)
-  **4307** – reflektor 1 pt.
-  155 (215 z adapterem) wys. | 100 (max 120) szer. | 100 g.
-  0,35
-  **4308** – zwis 1 pt.
-  675 (735 z adapterem) wys. | 100 szer. | 100 g.
-  0,4
-  możliwość wyboru długości rurki: 30 | 60 | 90 cm

HAGA 4322



HAGA 4323



HAGA 4324



HAGA 4325

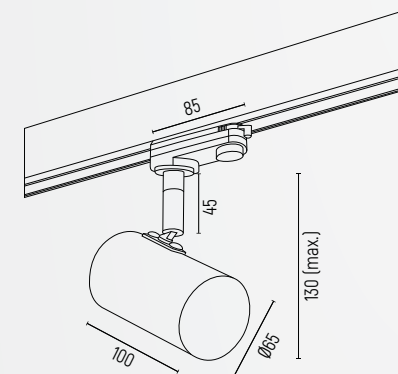

HAGA

-  **4322** – czarna struktura, el. mosiądzowane, czarny
-  **4323** – złoty struktura, el. mosiądzowane, czarny
-  **4324** – mosiądz, czarny
-  **4325** – biała struktura, el. mosiądzowane, czarny
-  reflektor LED
-  **4322, 4323, 4325** – stal lakierowana, tworzywo sztuczne
-  **4324** – stal mosiądzowana, tworzywo sztuczne
-  LED (zintegrowany) / 230V / 1100 lm / 3000 K | 1 x 9W
-  130 (190 z adapterem) wys. | 65 szer. | 100 g.
-  0,6

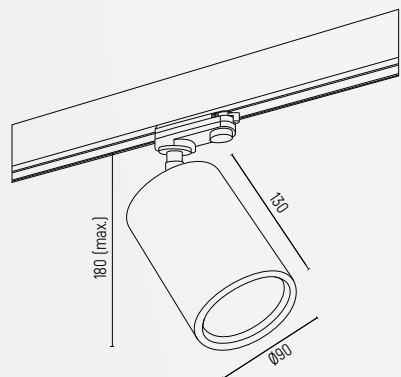





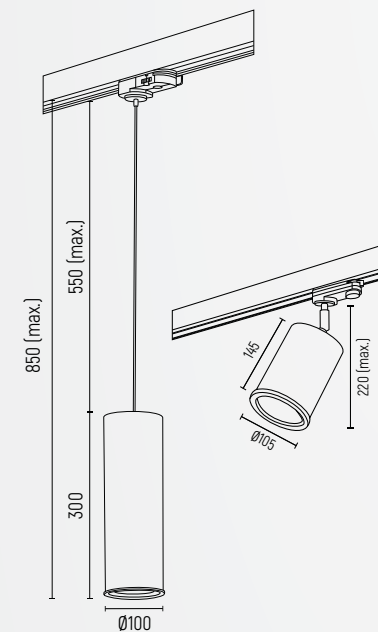



BERGEN

-  **4304** – złoty struktura, czarny
-  **4305** – biały struktura, czarny
-  **4306** – czarny struktura, czarny
-  reflektor 1 pt.
-  stal lakierowana, tworzywo sztuczne
-  E27 (nie zawiera źródła światła) / 230V | 1 x 15W (max)
-  180 (240 z adapterem) wys. | 90 szer. | 90 g.
-  0,6



DELFI

-  złoty, czarny struktura, czarny
-  abażur, stal lakierowana, tworzywo sztuczne
-  E27 (nie zawiera źródła światła) / 230V | 1 x 15W (max)
-  **4303** – reflektor 1 pt.
-  220 (280 z adapterem) wys. | 105 szer. | 145 g.
-  0,35
-  **4318** – zwis 1 pt.
-  850 (910 z adapterem) wys. | 100 szer. | 100 g.
-  0,5

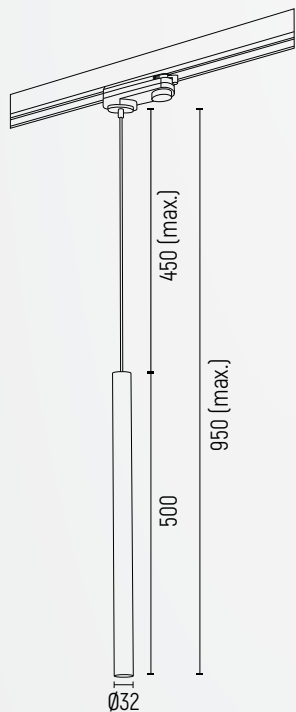

ELBRUS

-  **4319** - mosiądz, czarny
-  **4320** - czarny struktura, czarny
-  **4330** - biały struktura, czarny
-  zwis 1 pt. LED
-  **4319** - stal mosiądzowana, tworzywo sztuczne
-  **4320, 4330** - stal lakierowana, tworzywo sztuczne
-  LED (zintegrowany) / 230V / 560 lm / 3000 K | 1 x 4,5W
-  950 (1010 z adapterem) wys. | 32 szer. | 32 gt.
-  0,45

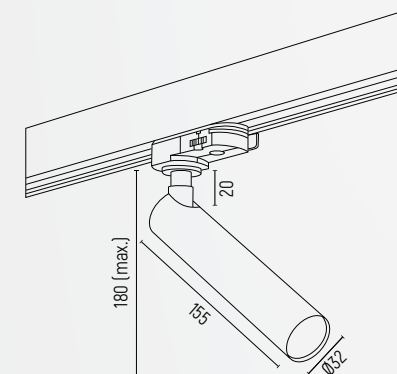

ELBRUS

-  **4353** - biały struktura, czarny
-  **4354** - mosiądz, czarny
-  **4355** - czarny struktura, czarny
-  reflektor LED
-  **4354** - stal mosiądzowana, tworzywo sztuczne
-  **4353, 4355** - stal lakierowana, tworzywo sztuczne
-  LED (zintegrowany) / 230V / 560 lm / 3000 K | 1 x 4,5W
-  180 (240 z adapterem) wys. | 32 szer. | 32 gt.
-  0,2

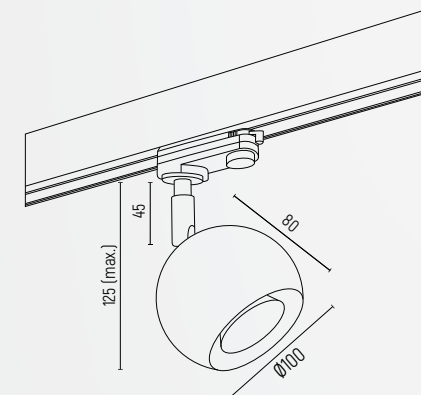
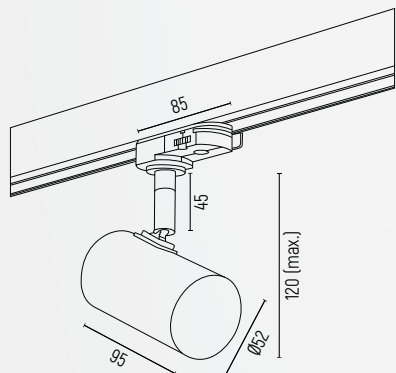

HORTA







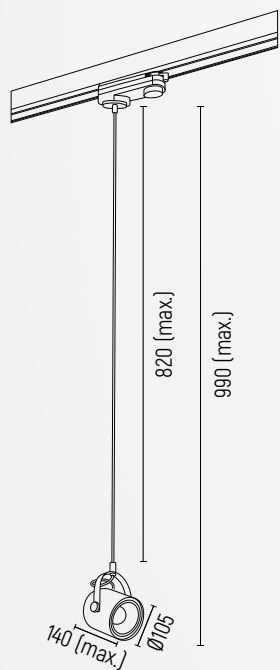



-  4327 – biały mat, czarny
-  4328 – mosiądz, czarny
-  4329 – czarny mat, czarny
-  reflektor 1 pt.
-  4327, 4329 – stal lakierowana, tworzywo sztuczne
-  4328 – stal mosiądzowana, tworzywo sztuczne
-  GU10 (nie zawiera źródła światła) / 230V | 1 x 5W
-  120 (180 z adapterem) wys. | 52 szer. | 95 gt.
-  0,4

MURI

-  4377 – biały struktura, czarny
-  4378 – mosiądz, czarny
-  4379 – czarny struktura, czarny
-  reflektor 1 pt.
-  4377, 4379 – stal lakierowana, tworzywo sztuczne
-  4378 – stal mosiądzowana, tworzywo sztuczne
-  GU10 (nie zawiera źródła światła) / 230V | 1 x 5W
-  125 (185 z adapterem) wys. | 100 szer. | 100 gt.
-  0,5



NET

-  **4312** - biały struktura, czarna struktura, czarny
-  **4313** - szalwia struktura, czarna struktura, czarny
-  **4314** - czarna struktura, el. mosiądzowane, czarny
-  zwis 1 pł. LED
-  **4312, 4313** stal lakierowana, tworzywo sztuczne
-  **4314** - stal lakierowana, el. mosiądzowane, tworzywo sztuczne
-  E27 (nie zawiera źródła światła) / 230V | 1 x 15W
-  990 (1050 z adapterem) wys. | 130 szer. | 140 gł.
-  0,85
-  możliwość wyboru długości rurki: 30 | 60 | 90 cm

NET 4312



NET 4313



NET 4314

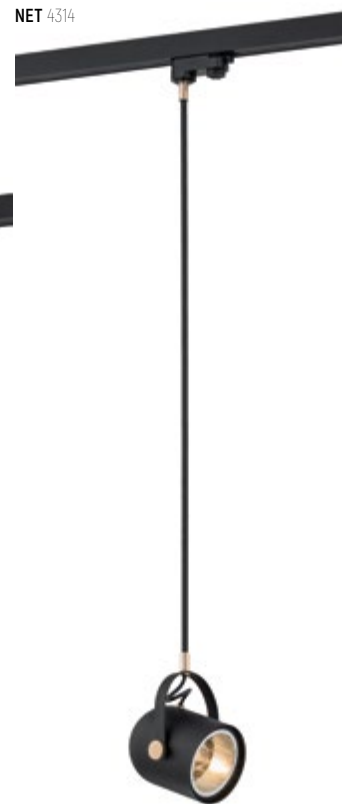

NET 4309



NET 4310



NET 4311

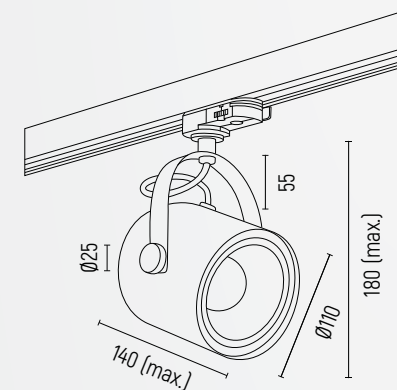

NET

-  **4309** - biały struktura, czarna struktura, czarny
-  **4310** - szalwia struktura, czarna struktura, czarny
-  **4311** - czarna struktura, el. mosiądzowane, czarny
-  reflektor 1 pł.
-  **4309, 4310** stal lakierowana, tworzywo sztuczne
-  **4311** - stal lakierowana, el. mosiądzowane, tworzywo sztuczne
-  E27 (nie zawiera źródła światła) / 230V | 1 x 15W
-  180 (240 z adapterem) wys. | 130 szer. | 140 gł.
-  0,7



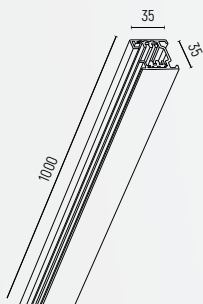

SZYNA 1M

- 4370 - czarny
- ☰ aluminium
- Ⓜ 35 wys. | 1000 szer. | 35 gt.
- Ⓚ 1

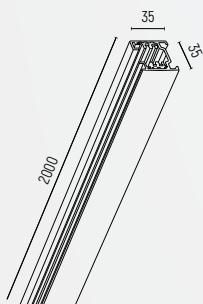

SZYNA 2M

- 4380 - czarny
- ☰ aluminium
- Ⓜ 35 wys. | 2000 szer. | 35 gt.
- Ⓚ 2



T-RACK SYSTEM 4370, 4380



T-RACK SYSTEM 4366



T-RACK SYSTEM 4367



T-RACK SYSTEM 4363



T-RACK SYSTEM 4368



T-RACK SYSTEM 4364



T-RACK SYSTEM 4369

KOŃCÓWKA ZASILAJĄCA

- 4366 - czarny
- ☰ tworzywo sztuczne
- Ⓜ 35 wys. | 115 szer. | 35 gt.
- Ⓚ 0,06

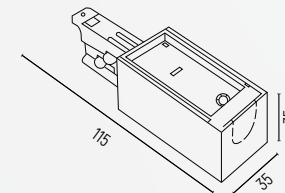

ŁĄCZNIK L

- 4367 - czarny
- ☰ tworzywo sztuczne
- Ⓜ 35 wys. | 110 szer. | 110 gt.
- Ⓚ 0,12

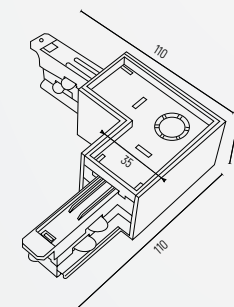

MOCOWANIE SUFITOWE

- 4368 - czarny
- ☰ tworzywo sztuczne
- Ⓜ 15 wys. | 45 szer. | 35 gt.
- Ⓚ 0,02

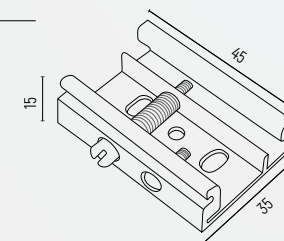

KOŃCÓWKA - ZAŚLEPKA

- 4369 - czarny
- ☰ tworzywo sztuczne
- Ⓜ 35 wys. | 35 szer. | 20 gt.
- Ⓚ 0,01

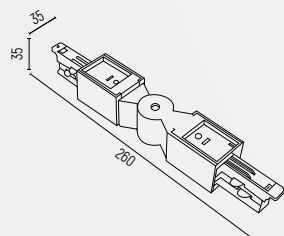
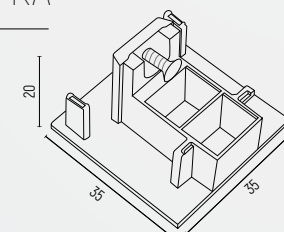

ŁĄCZNIK ŁAMANY

- 4363 - czarny
- ☰ tworzywo sztuczne
- Ⓜ 35 wys. | 260 szer. | 35 gt.
- Ⓚ 0,16

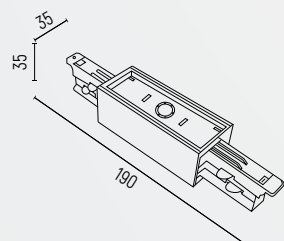





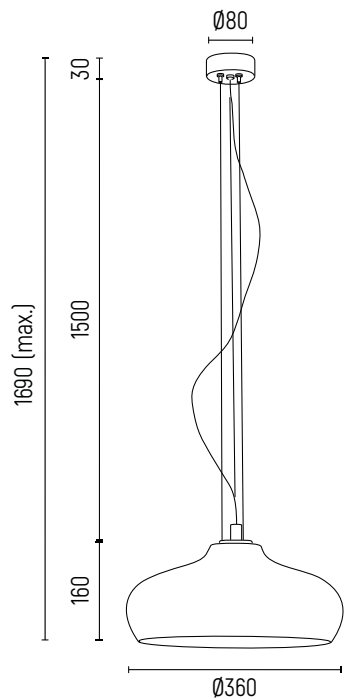

ŁĄCZNIK PROSTY

- 4364 - czarny
- ☰ tworzywo sztuczne
- Ⓜ 35 wys. | 190 szer. | 35 gt.
- Ⓚ 0,12



ALMERIA

-  4205 - transparentny, mosiądz
-  lampa wisząca 1 pt.
-  szkło, elementy mosiądzowane
-  E27 (nie zawiera źródła światła) / 230V | 1 x 15W (max)
-  linki max. 1500, całość 1690 wys. | 360 szer. | 360 gt.
-  4,7

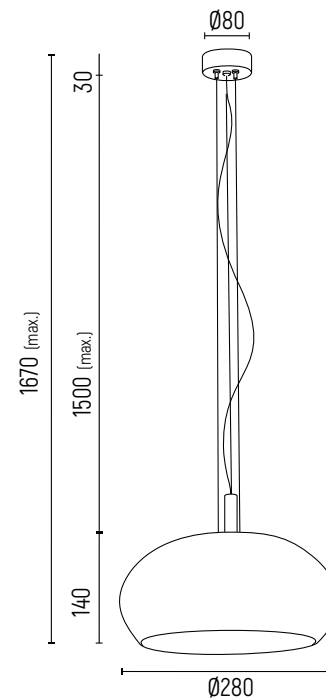

ALMERIA

-  4206 - transparentny, mosiądz
-  lampa wisząca 1 pt.
-  szkło, elementy mosiądzowane
-  E27 (nie zawiera źródła światła) / 230V | 1 x 15W (max)
-  max. 1500, całość 1670 wys. | 280 szer. | 280 gt.
-  4,5



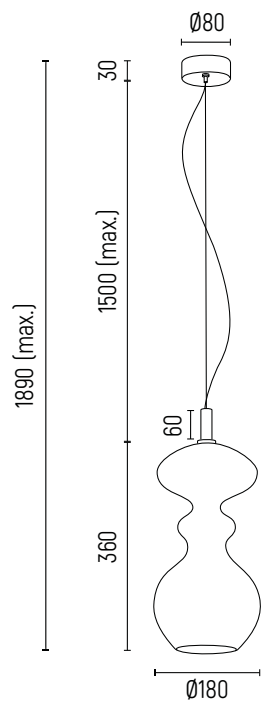

BILBAO 4203

BILBAO





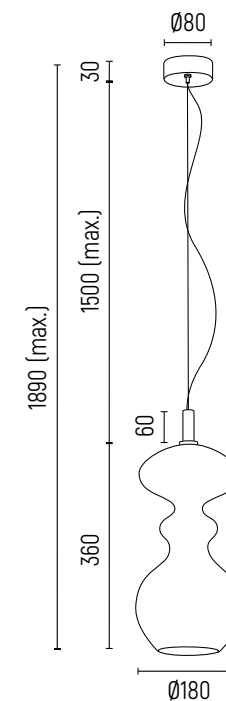

-  4203 - transparentny, mosiądz
-  lampa wisząca 1 pt.
-  szkło, elementy mosiądzowane
-  E27 (nie zawiera źródła światła) / 230V | 1 x 15W (max)
-  linka max. 1500, całość 1890 wys. | 180 szer. | 180 gt.
-  3,3



BILBAO 4204



BILBAO

-  4204 - transparentny, mosiądz
-  lampa wisząca 1 pt.
-  szkło, elementy mosiądzowane
-  E27 (nie zawiera źródła światła) / 230V | 1 x 15W (max)
-  linka max. 1500, całość 1890 wys. | 180 szer. | 180 gt.
-  3,3



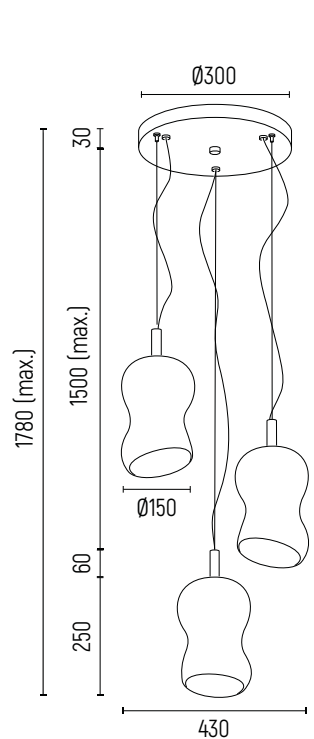





CADIZ 1464



CADIZ

-  1464 - transparentny, mosiądz
-  lampa wisząca 3 pt. na okrągłej podsufitce
-  szkło, elementy mosiądzowane
-  E27 (nie zawiera źródła światła) / 230V | 3 x 15W (max)
-  linka max. 1500, całość 1780 wys. | 430 szer. | 430 gt.
-  5,6





CRUZ

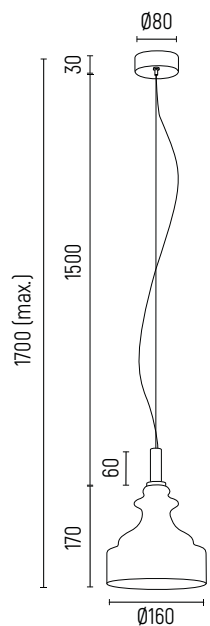
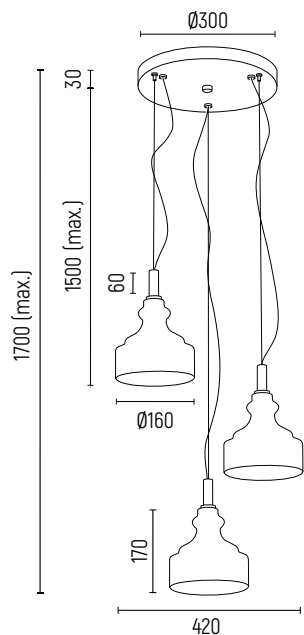

- transparentny, mosiądz
- szkło, elementy mosiądzowane

- 1462** - lampa wisząca 3 pt. na okrągłej podsufitce
- E14 (nie zawiera źródła światła) / 230V | 3 x 7W (max)
- linka max. 1500, całość 1700 wys. | 420 szer. | 420 gt.
- 4,6

- 4198** - lampa wisząca 1 pt.
- E14 (nie zawiera źródła światła) / 230V | 1 x 7W (max)
- linka max. 1500, całość 1700 wys. | 160 szer. | 160 gt.
- 1,8

- 4199** - kinkiet 1 pt.
- E14 (nie zawiera źródła światła) / 230V | 1 x 7W (max)
- 240 wys. | 160 szer. | 230 gt.
- 1,7

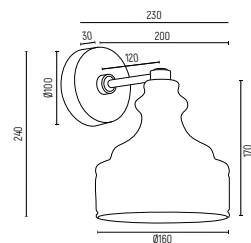

CRUZ 4199



CRUZ 1462



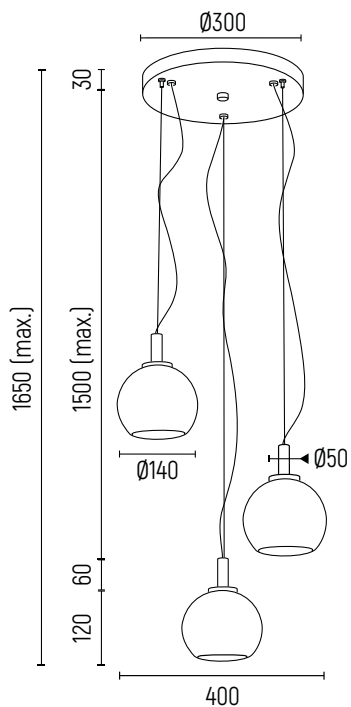

OVIEDO 1463



OVIEDO 4202

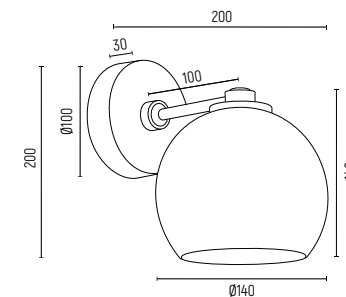

OVIEDO





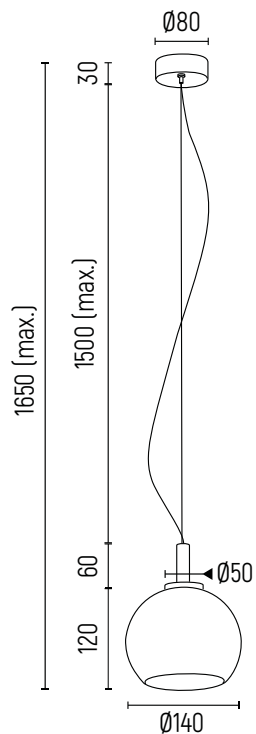

-  1463 - transparentny, mosiądz
-  lampa wisząca 3 pt. na okrągłej podsufitce
-  szkło, elementy mosiądzowane
-  E27 (nie zawiera źródła światła) / 230V | 3 x 15W (max)
-  linka max. 1500, całość 1650 wys. | 400 szer. | 400 gt.
-  3,2

OVIEDO

-  4202 - transparentny, mosiądz
-  kinkiet 1 pt.
-  szkło, elementy mosiądzowane
-  E27 (nie zawiera źródła światła) / 230V | 1 x 15W (max)
-  200 wys. | 140 szer. | 200 gt.
-  1,5







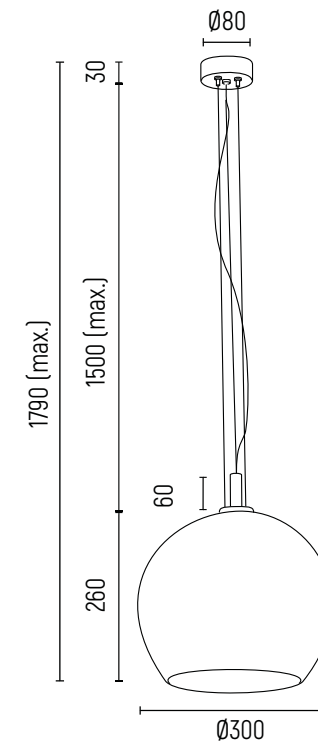

OVIEDO

-  4200 - transparentny, mosiądz
-  lampa wisząca 1 pł. mniejsza
-  szkło, elementy mosiądzowane
-  E27 (nie zawiera źródła światła) / 230V | 1 x 15W (max)
-  linka max. 1500, całość 1650 wys. | 140 szer. | 140 gt.
-  1,5

OVIEDO 4201



OVIEDO

-  4201 - transparentny, mosiądz
-  lampa wisząca 1 pł. większa
-  szkło, elementy mosiądzowane
-  E27 (nie zawiera źródła światła) / 230V | 1 x 15W (max)
-  linka max. 1500, całość 1790 wys. | 300 szer. | 300 gt.
-  3,7



ARGON

ul. Szkolna 258
42-261 Starcza
T: 34 314 02 50
mobile: 504 437 619

biuro@argon-lampy.pl
www.argon-lampy.pl